



# CREATIVE PIPING SOLUTIONS

*Innovating The Piping Industry*    [www.creativepiping.com](http://www.creativepiping.com)

## INDUSTRIAL FLANGES SPECIFICATIONS AND DIMENSIONS



Creative Piping Solutions (CPS) is a trusted name in the industry, backed by over three decades of expertise in manufacturing pipe fittings, flanges, forged fittings, and fabrication works. Our unwavering commitment to quality, innovation, and sustainability enables us to deliver world-class products at competitive prices, meeting the diverse needs of our global clientele.



# Flanges



A flange is designed to connect sections of pipe or tube, or to join the pipe or tube to an assembly such as a pressure vessel, valve or pump. Flanges are joined by bolting, and sealing is completed with the use of gaskets and other sealing methods, and fixed to the piping system by welding or threading.

A comprehensive range of Table D and E flanges to AS 2129, and forged flanges to ASME standards in ratings of class, are stocked by Creative Piping Solutions throughout Australia in sizes DN 15 (NPS 1/2") though to DN 400 (NPS 16").

Larger sizes to DN 1500 (NPS 60") and ratings to Class 2500 are also available through our worldwide network of quality approved mills and stockists.

Standard stocks include 304L and 316L stainless steels, with many other materials available on request

including Cr-Mo, low temperature alloys, nickel based alloys and duplex grades. All flanges can be supplied complete with material certificates in strict accordance with the applicable standards, under the control of Creative Piping Solutions's ISO 9001:2008 quality assurance program.

## FLANGE FACINGS

The most common types of flange facings are:-

- Flat Face (commonly used on AS 2129 Flanges) and
- Raised Face (commonly used on ASME Flanges)

Other facings include:-

- Ring-Joint (RTJ)
- Tongue and Groove
- Male and Female (Spigot and Recess)
- O-Ring Groove (O-Ring Spigot and O-Ring Groove)



## MANUFACTURING STANDARDS

In Australia, flanges are commonly manufactured to the following standards:

### 1. AS 2129 – Flanges for Pipes, Valves and Fittings

They are commonly known as "Table" flanges, (e.g. Table D) and are usually made from plate or forgings, hence the pipe bore and tube bore slip-on or blind are the most common forms.

The standard covers nominal sizes DN 15 (NPS 1/2") to DN 3000 (NPS 120") in Table D, and DN 1200 (NPS 48") in Table E, but flanges up to DN 400 (NPS 16") are normally available off the shelf, in 304(L) or 316(L) grades. The F and Table H flanges are also reasonably popular and a range is carried off the shelf. The other rating classes of Table A, J, K, R, S and T are less common usage than Table D or E.

### 2. AS 4087 – Metallic Flanges for Waterworks Purposes

Formerly included in AS 2129, this standard covers nominal sizes of DN 15 (NPS 1/2") to DN 1200 (NPS 48") in various materials and pressure ratings designated by their allowable operating pressure (AOP) – PN Rating – but the nominal size range is limited to DN 50 (NPS 2") to DN 1200 (NPS 48") with pressure ratings of PN 16, PN 21 and PN 35 for stainless steel grades of material. These flanges are generally stocked in sizes DN 50 (NPS 2") to DN 600 (NPS 24") with a PN 16 pressure rating. The other sizes and pressure ratings are available with a lead time.

### 3. ASME B16.5 - Pipe Flanges and Fittings

These are commonly referred to by their pressure rating class, (e.g. ANSI 150 or 150lb). This standard specifies that for the standard 304(L) and 316(L) grades, the flanges must be forged, (except for blind flanges which can be made from plate).

The most commonly stocked flanges are slip-on, weld neck and blind. (Note that the slip-on flange has a hub similar to the lap joint flange and they should not be misinterpreted).

The standard covers sizes up to DN 15 (NPS 1/2") to DN 600 (NPS 24"), in Class ratings of 150, 300, 400, 600, 900, 1500 and 2500.

### 4. ASME B16.47 - Large Diameter Steel Flanges

This standard covers the size range of DN 650 (NPS 26") to DN 1500 (NPS 60"). In Series A, Class ratings of 150, 300, 400, 600 and 900 are covered. In Series B, Class ratings of 150, 300, 400, 600 and 900 are covered. These flanges are not commonly stocked, but are available on a lead time.

### 5. ASME B16.36 - Orifice Flanges

This standard covers DN 25 (NPS 1") to DN 600 (NPS 24") in Class ratings of 300, 400, 600, 900, 1500 and 2500. These flanges are not commonly stocked, but are available on a lead time.

### 6. ASME B16.48 – Line Blanks

The standard covers a range of line blanks in nominal sizes DN 15 (NPS 1/2") to DN 600 (NPS 24") for installation between ASME B16.5 flanges in Class ratings of 150, 300, 600, 900, 1500 and 2500 and replaces the API 590 Standard. The facing finishes are in accordance with ASME B16.5 and are listed as raised face, male ring-joint and female ring-joint.

The Line Blanks come in different configurations and they are defined as:-

**Figure-8 Blank** - A figure-8 blank (also known as a spectacle blank or blind) is a pressure retaining plate with one solid end and the other end is open. The two ends are connected with a web or tie bar.

**Paddle Blank** - A paddle blank (also known as a spade blind) is similar to the solid end of a figure-8 blank. It has a plain radial handle and it is generally used in conjunction with a paddle spacer in larger sizes.

**Paddle Spacer** - A paddle spacer (also known as a ring spacer) is similar to the open end of a figure-8 blank. It has a plain radial handle and it is generally used in conjunction with a paddle blank in larger sizes.

### 7. EN 1092-1 Flanges and their Joints – Circular Flanges for Pipes, Valves, Fittings and Accessories, PN Designated – Part 1: Steel Flanges

The flanges listed in this standard have been derived from various other standards around the world. This standard encompasses flanges that were listed in BS 4504-3.1 and ISO 7005-1 and the opportunity was taken to revise some of the technical requirements applicable to DIN origin flanges.

The standard covers nominal sizes DN 10 (NPS 3/8") to DN 4000 (NPS 160") with pressure designations PN 2.5 to PN 400. These flanges are generally stocked in sizes DN 25 (NPS 1") to DN 300 (NPS 12") with a pressure designation of PN 16 in pipe bore and tube bore slip-on, along with blind flanges.

Other standards in less common use or that may appear on old specifications include:

BS 1560 Section 3.1 – Circular Flanges for Pipes, Valves and Fittings (class designated). This has been now superseded by EN 1759-1.

BS 4504-3.1 – Circular flanges for pipes, valves and fittings (PN designated). Steel, cast iron and copper alloy flanges. Specification for steel flanges. This standard has been now superseded by EN 1092-1.

EN 1759-1 – Flanges and their Joints. Circular Flanges for Pipes, Valves, Fittings and Accessories, class-designated. Steel Flanges, NPS 1/2 to 24.

ISO 7005-1 – Pipe Flanges – Part 1: Steel Flanges for Industrial and General Service Piping Systems

DIN – There are a range of DIN standards which cover flanges and these include but are not limited to the DIN 2500 and DIN 2600 series of standards. The DIN 2500 and DIN 2600 series of standards have been replaced by EN 1092-1.







**Table Flanges**



**Raised Face Weld Neck Flanges**



**Threaded Flanges**



**Raised Face Slip-On (left)  
and Socketweld Flanges**



**Raised Face Blind Flanges**



**Blind Plate Flanges**



**TYPES AND APPLICATIONS**

**Slip-On Weld Flange** – The flange is slipped over the pipe or tube and welded (usually both inside and outside) to provide strength and to prevent leaks. These flanges are at the low cost end of the scale, and do not require high accuracy when cutting the pipe or tube to length. They can sometimes have a boss or hub, and can be made with a bore to suit pipe or tube.

**Weld Neck Flange** – This flange is designed to be joined to a piping system by butt welding. It is relatively expensive because of its long neck, but is preferred for high stress applications. The neck transmits stresses to the pipe, reducing stress concentrations at the base of the flange. The gradual transition of thickness from the base to the neck to the wall thickness at the butt weld provides important reinforcement of the flange. The bore of the flange matches the bore of the pipe, reducing turbulence and erosion.

**Threaded Flange** – This is similar to the slip-on flange in outline, but the bore is threaded, thus enabling assembly without welding. This obviously limits its application to relatively low pressure piping systems. The flange may be welded around the joint after assembly, but this is not considered a satisfactory method of increasing its use in pressure applications.

**Socketweld Flange** – This is similar to a slip-on flange in outline, but the bore is counter-bored to accept the pipe. The diameter of the remaining bore is the same as the inside diameter of the pipe. The flange is attached to the pipe by a fillet weld around the hub of the flange. An optional internal weld may be applied in high stress applications. Its biggest use is in high pressure systems such as hydraulic and steam lines.

**Lap Joint Flange** – This is again similar to a slip-on flange, but it has a radius at the intersection of the bore and the flange face, and no raised face, to accommodate a lap joint stub end. The face of the stub end forms the gasket face of the flange. This type of flange is used in applications where sections of the piping system need to be dismantled quickly and easily for inspection or replacement, because the stub end is welded to the pipe, not the flange. As the flange is not welded to the pipe, this allows for easy alignment to the mating flange.

**Blind Flange** – This is a flange without a bore and is used to shut off a piping system or vessel opening. It also permits easy access to vessels or piping systems for inspection purposes.

**Loose Flange** – This is usually used with a pressed collar, where the flange is placed behind the collar before the collar is welded to the pipe or tube. The flange is not welded, and thus allows for easy alignment. As the flange is not in direct contact with the liquid, alternative materials can be used for the flange.



**Lap Joint**



**Flanged Butt weld Outlets and Flanged Butt weld Nipple Outlets**



**Forged Flanges Class 150 – Class 2500**



**Spectacle Blind**



AS 2129 TABLE FLANGES TABLE D

Size		Bolting Details				Bolting Details		Welding Neck			Boss Details				
DN mm	Nominal Pipe Size inch	Outside Diameter of Flange A	Forged or Plate; Thickness of Flange Min. B	Pitch Circle Diameter C	Number of Holes D	Diameter of Holes E	Diameter of Bolts Metric	Slip-On or Bossed F	Welding Neck F1	Total Length of Neck G	Diameter at Small End of Neck H	Diameter at Large End of Neck J	Length of Boss Details K	Diameter of Boss at Small End Min. L	Diameter at Root of Boss Max. M
15	1/2	95	5*	67	4	14	M12	BORE OF FLANGES TO SUIT EITHER PIPE OR TUBE OD - REFER PIPE & TUBE DIMENSIONS ON PAGES 36 & 37	BORE TO SUIT PIPE SCHEDULE - TO BE SPECIFIED BY THE PURCHASER	22	22	27	10	33	38
20	3/4	100	5*	73	4	14	M12			22	27	33	11	38	44
25	1	115	5*	83	4	14	M12			22	34	43	11	48	52
32	1-1/4	120	6*	87	4	14	M12			25	43	49	11	56	58
40	1-1/2	135	6*	98	4	14	M12			29	49	59	13	62	70
50	2	150	8*	114	4	18	M16			29	61	70	13	75	79
65	2-1/2	165	8*	127	4	18	M16			32	76	83	16	90	93
80	3	185	10*	146	4	18	M16			35	89	102	16	106	112
100	4	215	10*	178	4	18	M16			41	115	130	19	133	140
125	5	255	13	210	8	18	M16			44	142	152	19	160	171
150	6	280	13	235	8	18	M16			48	169	184	19	186	197
200	8	335	13	292	8	22	M20			51	220	241	22	241	254
250	10	405	16	356	8	22	M20			64	274	292	27	298	310
300	12	455	19	406	12	26	M24			70	324	343	29	349	360
350	14	525	22	470	12	26	M24			73	356	387	-	-	-
400	16	580	22	521	12	26	M24			-	-	-	-	-	-
450	18	640	25	584	12	26	M24			-	-	-	-	-	-
500	20	705	29	641	16	26	M24			-	-	-	-	-	-
600	24	825	32	756	16	30	M27			-	-	-	-	-	-

\*Flanges less than 12 mm thickness may suffer unacceptable distortion after welding to pipe.

Size		Approximate piece weight in Kilograms		
DN mm	NPS inch	Blind	Pipe Slip-On	Tube Slip-On
15	1/2	0.26	0.24	0.25
20	3/4	0.29	0.27	0.28
25	1	0.39	0.36	0.37
32	1-1/4	0.51	0.45	0.48
40	1-1/2	0.66	0.57	0.60
50	2	1.1	0.88	0.94
65	2-1/2	1.3	1.0	1.1
80	3	2.1	1.6	1.7
100	4	2.8	2.0	2.2
125	5	5.1	3.5	3.8
150	6	6.2	3.9	4.3
200	8	9.0	5.0	5.6
250	10	16.1	8.6	9.6
300	12	24.0	11.5	12.9
350	14	37.0	19.5	19.5
400	16	45.4	22.5	22.5
450	18	63.1	30.3	30.2
500	20	88.6	41.6	41.6
600	24	134.0	59.1	59.2

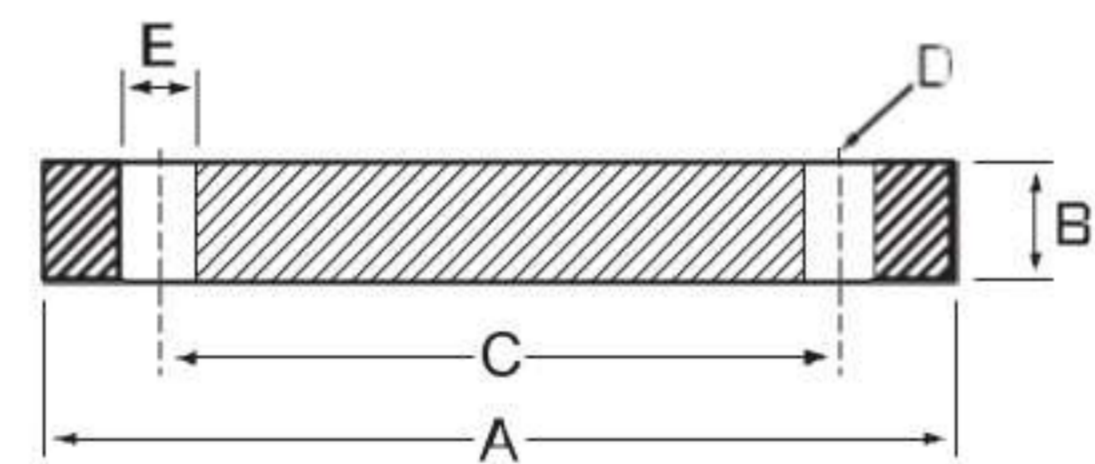

BLIND

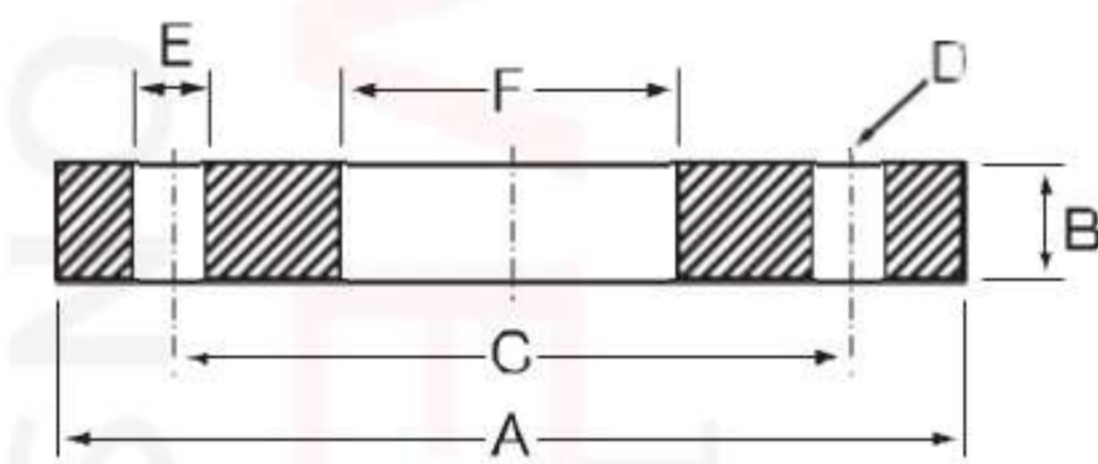

SLIP-ON WELDING

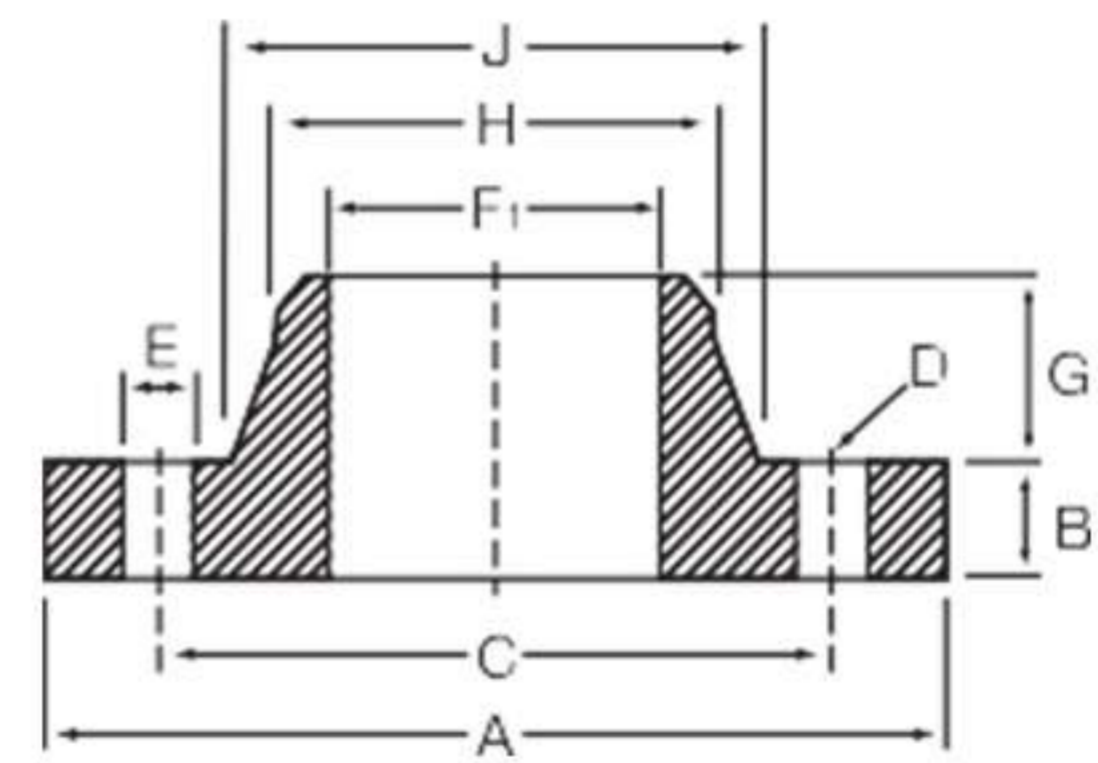

WELDING NECK

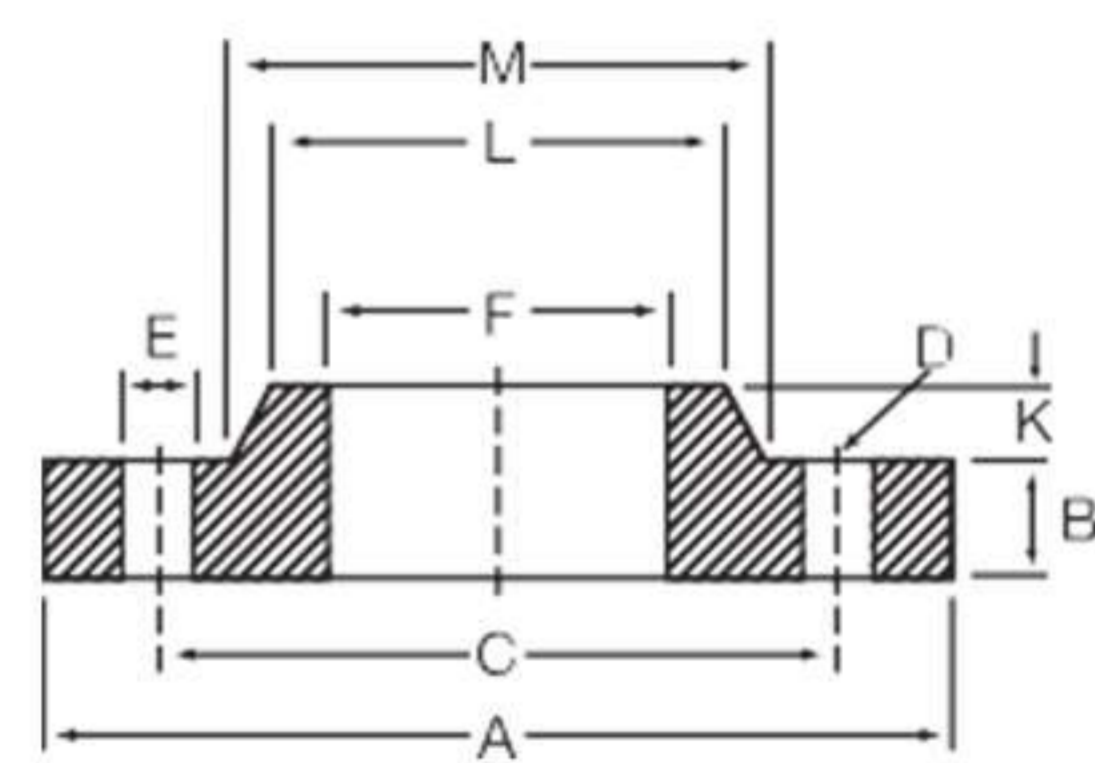

BOSSED

Notes:

1. All dimensions are in millimetres.
2. Only the Flat Face variant of each type of flange has been illustrated as they are the most commonly available. Other variants available are Raised Face, Flat with O-Ring Groove or Spot-Faced and other flange facing types may change the "B" dimension, please contact your local Creative Piping Solutions office for more information.
3. For Threaded Flanges a Boss Flange is used to accommodate the thread. The Thread Form and Thread Type are not specified in the Standard, please contact your local Creative Piping Solutions office for more information.
4. All weights are approximates only.



AS 2129 TABLE FLANGES TABLE E

Size		Bolting Details						Bolting Details		Welding Neck			Boss Details		
DN mm	Nominal Pipe Size inch	Outside Diameter of Flange A	Forged or Plate; Thickness of Flange Min. B	Pitch Circle Diameter C	Number of Holes D	Diameter of Holes E	Diameter of Bolts Metric	Slip-On or Bossed F	Welding Neck F1	Total Length of Neck G	Diameter at Small End of Neck H	Diameter at Large End of Neck J	Length of Boss Details K	Diameter of Boss at Small End Min. L	Diameter at Root of Boss Max. M
15	1/2	95	6*	67	4	14	M12	BORE OF FLANGES TO SUIT EITHER PIPE OR TUBE OD - REFER PIPE & TUBE DIMENSIONS ON PAGES 36 & 37	TO BE SPECIFIED BY THE PURCHASER	22	22	27	10	33	38
20	3/4	100	6*	73	4	14	M12			22	27	33	11	38	44
25	1	115	7*	83	4	14	M12			22	34	43	11	48	52
32	1-1/4	120	8*	87	4	14	M12			25	43	49	11	56	58
40	1-1/2	135	9*	98	4	14	M12			29	49	59	13	62	70
50	2	150	10*	114	4	18	M16			29	61	70	13	75	79
65	2-1/2	165	10*	127	4	18	M16			32	76	83	16	90	93
80	3	185	11*	146	4	18	M16			35	89	102	16	106	112
100	4	215	13	178	8	18	M16			41	102	130	19	133	140
125	5	255	14	210	8	18	M16			44	142	152	19	160	171
150	6	280	17	235	8	22	M20			48	169	184	19	186	191
200	8	335	19	292	8	22	M20			51	220	241	22	241	249
250	10	405	22	356	12	22	M20			64	274	292	27	298	310
300	12	455	25	406	12	26	M24			70	324	343	29	349	354
350	14	525	29	470	12	26	M24			73	356	387	-	-	-
400	16	580	32	521	12	26	M24			-	-	-	-	-	-
450	18	640	35	584	16	26	M24			-	-	-	-	-	-
500	20	705	38	641	16	26	M24			-	-	-	-	-	-
600	24	825	48	756	16	33	M30			-	-	-	-	-	-

\*Flanges less than 12 mm thickness may suffer unacceptable distortion after welding to pipe.

Size		Approximate piece weight in Kilograms		
DN mm	NPS inch	Blind	Pipe Slip-On	Tube Slip-On
15	1/2	0.31	0.29	0.30
20	3/4	0.35	0.32	0.33
25	1	0.55	0.50	0.52
32	1-1/4	0.68	0.59	0.63
40	1-1/2	0.99	0.85	0.90
50	2	1.3	1.1	1.2
65	2-1/2	1.6	1.3	1.4
80	3	2.3	1.7	1.9
100	4	3.6	2.5	2.7
125	5	5.5	3.7	4.1
150	6	8.0	4.9	5.5
200	8	12.9	7.2	8.0
250	10	21.9	11.6	13.0
300	12	31.2	14.8	16.7
350	14	48.7	25.7	25.7
400	16	66.0	32.8	32.8
450	18	87.7	41.8	41.7
500	20	116.1	54.5	54.5
600	24	200.0	87.8	87.9

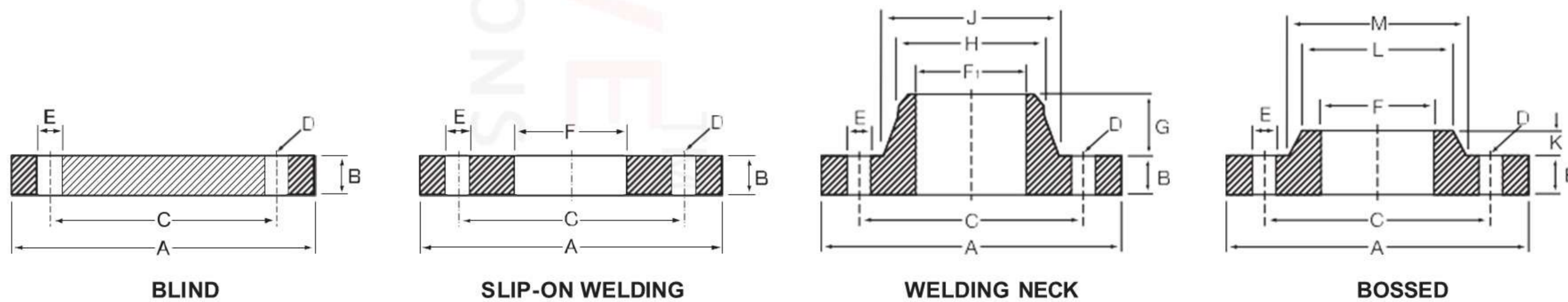

Notes:

1. All dimensions are in millimetres.
2. Only the Flat Face variant of each type of flange has been illustrated as they are the most commonly available. Other variants available are Raised Face, Flat with O-Ring Groove or Spot-Faced and other flange facing types may change the "B" dimension.
3. For Threaded Flanges a Boss Flange is used to accommodate the thread. The Thread Form and Thread Type are not specified in the Standard, please contact your local Creative Piping Solutions office for more information.
4. All weights are approximates only.



Size		Bolting Details						Bolting Details		Welding Neck			Boss Details		
DN mm	Nominal Pipe Size inch	Outside Diameter of Flange A	Forged or Plate; Thickness of Flange Min. B	Pitch Circle Diameter C	Number of Holes D	Diameter of Holes E	Diameter of Bolts Metric	Slip-On or Bossed F	Welding Neck F1	Total Length of Neck G	Diameter at Small End of Neck H	Diameter at Large End of Neck J	Length of Boss Details K	Diameter of Boss at Small End Min. L	Diameter at Root of Boss Max. M
15	1/2	95	10*	67	4	14	M12	BORE OF FLANGES TO SUIT EITHER PIPE OR TUBE OD - REFER PIPE & TUBE DIMENSIONS ON PAGES 36 & 37	TO BE SPECIFIED BY THE PURCHASER	22	22	27	10	33	38
20	3/4	100	10*	73	4	14	M12			22	27	33	11	38	44
25	1	120	10*	87	4	18	M16			29	34	43	11	48	52
32	1-1/4	135	13	98	4	18	M16			35	43	52	11	56	64
40	1-1/2	140	13	105	4	18	M16			35	49	59	13	62	70
50	2	165	16	127	4	18	M16			35	61	70	13	75	93
65	2-1/2	185	16	146	8	18	M16			38	76	86	16	90	112
80	3	205	16	165	8	18	M16			44	89	102	16	106	130
100	4	230	19	191	8	18	M16			51	115	130	19	133	152
125	5	280	22	235	8	22	M20			57	142	159	19	160	191
150	6	305	22	260	12	22	M20			57	169	184	19	186	216
200	8	370	25	324	12	22	M20			67	220	241	22	241	279
250	10	430	29	381	12	26	M24			73	274	298	27	298	329
300	12	490	32	438	16	26	M24			79	324	352	29	349	386
350	14	550	35	495	16	30	M27			86	356	387	-	-	-
400	16	610	41	552	20	30	M27			-	-	-	-	-	-
450	18	675	44	610	20	33	M30			-	-	-	-	-	-
500	20	735	51	673	24	33	M30			-	-	-	-	-	-
600	24	850	57	781	24	36	M30			-	-	-	-	-	-

Size		Approximate piece weight in Kilograms		
DN mm	NPS inch	Blind	Pipe Slip-On	Tube Slip-On
15	1/2	0.52	0.49	0.51
20	3/4	0.58	0.53	0.56
25	1	0.82	0.75	0.78
32	1-1/4	1.4	1.2	1.3
40	1-1/2	1.5	1.3	1.4
50	2	2.6	2.2	2.3
65	2-1/2	3.2	2.6	2.8
80	3	4.0	3.2	3.4
100	4	6.0	4.4	4.8
125	5	10.3	7.5	8.1
150	6	12.1	8.1	8.8
200	8	20.6	13.1	14.1
250	10	32.2	18.6	20.5
300	12	46.1	25.0	27.4
350	14	63.4	35.5	35.5
400	16	91.2	48.7	48.7
450	18	119.9	62.2	62.2
500	20	164.7	82.0	82.0
600	24	247.6	114.4	114.5

\*Flanges less than 12 mm thickness may suffer unacceptable distortion after welding to pipe.

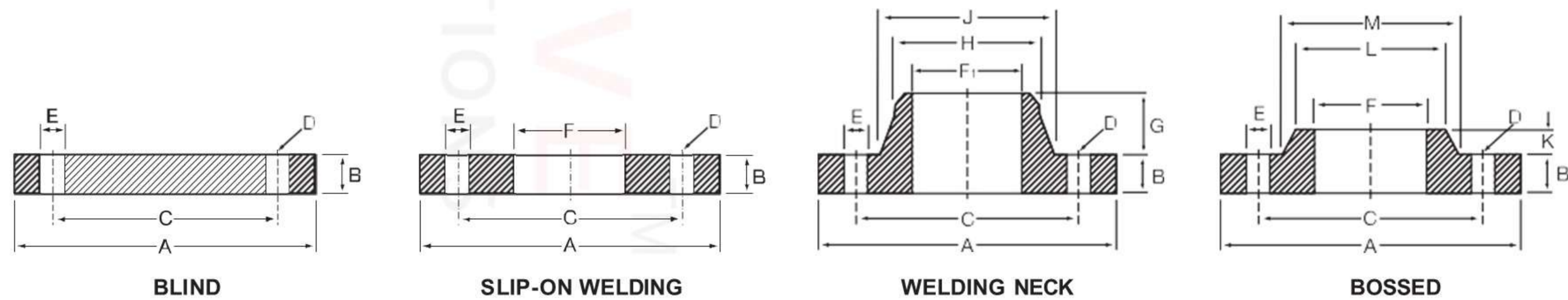

**Notes:**

1. All dimensions are in millimetres.
2. Only the Flat Face variant of each type of flange has been illustrated as they are the most commonly available. Other variants available are Raised Face, Flat with O-Ring Groove or Spot-Faced and other flange facing types may change the "B" dimension, please contact your local Creative Piping Solutions office for more information.
3. For Threaded Flanges a Boss Flange is used to accommodate the thread. The Thread Form and Thread Type are not specified in the Standard, please contact your local Creative Piping Solutions office for more information.
4. All weights are approximates only.

AS 2129 TABLE FLANGES TABLE F



Size		Bolting Details						Bolting Details		Welding Neck			Boss Details		
DN (metric)	Nominal Pipe Size (inch)	Outside Diameter of Flange A	Forged or Plate; Thickness of Flange Min. B	Pitch Circle Diameter C	Number of Holes D	Diameter of Holes E	Diameter of Bolts Metric	Slip-On or Bossed F	Welding Neck F1	Total Length of Neck G	Diameter at Small End of Neck H	Diameter at Large End of Neck J	Length of Boss Details K	Diameter of Boss at Small End Min. L	Diameter at Root of Boss Max. M
15	1/2	115	13	83	4	18	M16	BORE OF FLANGES TO SUIT EITHER PIPE OR TUBE OD - REFER PIPE & TUBE DIMENSIONS ON PAGES 36 & 37	TO BE SPECIFIED BY THE PURCHASER	29	22	30	10	33	48
20	3/4	115	13	83	4	18	M16			29	27	35	11	38	48
25	1	120	14	87	4	18	M16			29	34	43	11	48	52
32	1-1/4	135	17	98	4	18	M16			35	43	52	11	56	64
40	1-1/2	140	17	105	4	18	M16			35	49	59	13	62	70
50	2	165	19	127	4	18	M16			35	61	70	13	75	93
65	2-1/2	185	19	146	8	18	M16			38	76	86	16	90	112
80	3	205	22	165	8	18	M16			44	89	102	16	106	130
100	4	230	25	191	8	18	M16			51	115	130	19	133	152
125	5	280	29	235	8	22	M20			57	142	159	19	160	191
150	6	305	29	260	12	22	M20			57	169	184	19	186	216
200	8	370	32	324	12	22	M20			67	220	241	22	241	279
250	10	430	35	371	12	26	M24			73	274	298	27	298	329
300	12	490	41	438	16	26	M24			79	324	352	29	349	386
350	14	550	48	495	16	30	M27			86	356	387	-	-	-
400	16	610	54	552	20	30	M27			-	-	-	-	-	-
450	18	675	60	610	20	33	M30			-	-	-	-	-	-
500	20	735	67	673	24	33	M30			-	-	-	-	-	-
600	24	850	76	781	24	36	M33			-	-	-	-	-	-

Size		Approximate piece weight in Kilograms		
DN mm	NPS inch	Blind	Pipe Slip-On	Tube Slip-On
15	1/2	0.97	0.94	0.96
20	3/4	0.97	0.92	0.94
25	1	1.2	1.1	1.1
32	1-1/4	1.8	1.6	1.7
40	1-1/2	2.0	1.7	1.8
50	2	3.1	2.7	2.8
65	2-1/2	3.8	3.1	3.3
80	3	5.5	4.4	4.6
100	4	7.9	5.9	6.3
125	5	13.6	9.9	10.6
150	6	15.9	10.7	11.7
200	8	26.4	16.7	18.1
250	10	38.9	22.5	24.7
300	12	59.1	32.0	35.1
350	14	86.9	48.8	48.8
400	16	120.1	64.1	64.1
450	18	163.6	84.8	84.8
500	20	216.4	107.8	107.8
600	24	330.2	152.5	152.7

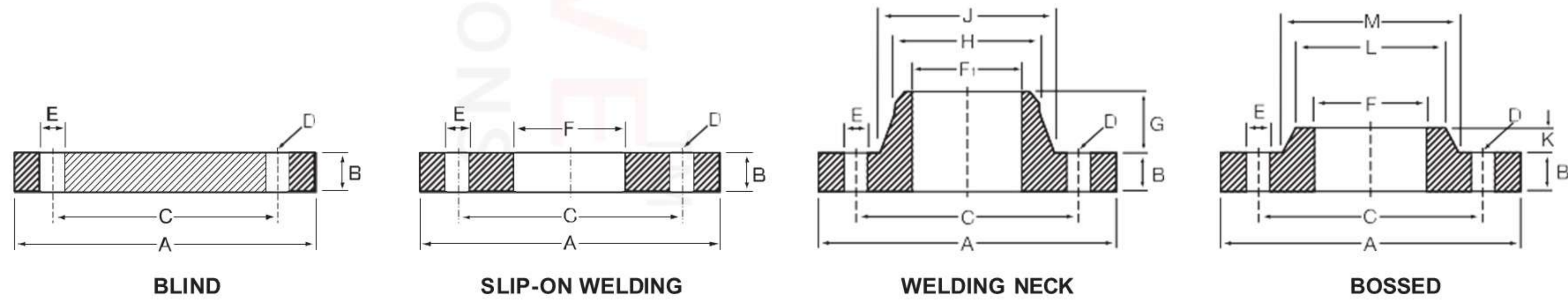

**Notes:**

1. All dimensions are in millimetres.
2. Only the Flat Face variant of each type of flange has been illustrated as they are the most commonly available. Other variants available are Raised Face, Flat with O-Ring Groove or Spot-Faced and other flange facing types may change the "B" dimension, please contact your local Creative Piping Solutions office for more information.
3. For Threaded Flanges a Boss Flange is used to accommodate the thread. The Thread Form and Thread Type are not specified in the Standard, please contact your local Creative Piping Solutions office for more information.
4. All weights are approximates only.

AS 2129 TABLE FLANGES TABLE H



## TEMPERATURE/PRESSURE RATINGS FOR STAINLESS STEEL TABLE FLANGES

Temperature = °C and Pressure = kPa

Temperature	TABLE D		TABLE E		TABLE F		TABLE H	
	316, 304	316L, 304L	316, 304	316L, 304L	316, 304	316L, 304L	316, 304	316L, 304L
-200 to 50	700	700	1400	1400	2100	2100	3500	3500
100	700	700	1400	1400	2100	2100	3500	3500
150	700	650	1400	1300	2100	1900	3500	3200
200	650	600	1300	1200	2000	1800	3300	2900
250	650	550	1300	1100	1900	1700	3200	2800
275	600	550	1200	1100	1800	1600	3100	2800
300	570	550	1100	1100	1700	1600	2900	2800
325	550	550	1000	1000	1600	1600	2600	2600
350	500	500	950	950	1400	1400	2400	2400
375	450	450	900	900	1300	1300	2200	2200
400	400	400	800	800	1200	1200	2000	2000
425	350	350	700	700	1000	1000	1700	1700
450	-	-	-	-	-	-	1300	1300
475	-	-	-	-	-	-	900	900

**Notes:**

1. The Temperature/Pressure information was obtained from AS 2129-2000. For full details regarding Temperature/Pressure ratings of other materials, refer to the standard.
2. Pressure Ratings are maximum allowable working gauge pressures in kPa at the temperatures shown for the applicable material and Table designation.



# EN 1092-1 DIN FLANGES

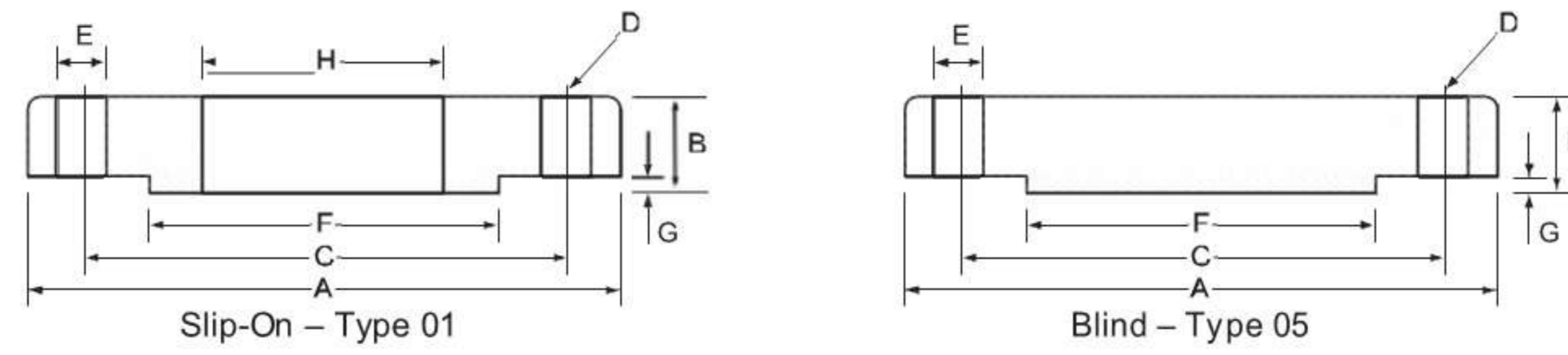

## PN 06

Size		Bolting Details									Bore	Masses of flanges	
DN mm	Nominal Pipe Size inch	Outside Diam. of Flange A	Forged or Plate; Thickness of Flange Min. B1-Type01	Forged or Plate; Thickness of Flange Min. B2-Type05	Pitch Circle Diam. C	Number of Holes D	Diam. of Holes E	Diam. of Bolts Metric	Diam. of Raised Face F	Height of Raised Face G	Slip-On H	Type 01 (kg)	Type 05 (kg)
10	3/8	75	12	12	50	4	11	M10	35	2	BORE OF FLANGES TO SUIT EITHER PIPE OR TUBE OD - REFER PIPE & TUBE DIMENSIONS ON PAGES 36 & 37	0.36	0.38
15	1/2	80	12	12	55	4	11	M10	40	2		0.40	0.44
20	3/4	90	14	14	65	4	11	M10	50	2		0.59	0.66
25	1	100	14	14	75	4	11	M10	60	2		0.72	0.82
32	1-1/4	120	16	14	90	4	14	M12	70	2		1.16	1.18
40	1-1/2	130	16	14	100	4	14	M12	80	3		1.35	1.39
50	2	140	16	14	110	4	14	M12	90	3		1.48	1.62
65	2-1/2	160	16	14	130	4	14	M12	110	3		1.86	2.14
80	3	190	18	16	150	4	18	M16	128	3		2.95	3.43
100	4	210	18	16	170	4	18	M16	148	3		3.26	4.22
125	5	240	20	18	200	8	18	M16	178	3		4.31	6.10
150	6	265	20	18	225	8	18	M16	202	3		4.76	7.51
200	8	320	22	20	280	8	18	M16	258	3		6.88	12.30
250	10	375	24	22	335	12	18	M16	312	3		8.92	18.50
300	12	440	24	22	395	12	22	M20	365	4		11.90	25.50
350	14	490	26	22	445	12	22	M20	415	4		16.80	31.80
400	16	540	28	22	495	16	22	M20	465	4		19.80	38.50
450	18	595	30	24	550	16	22	M20	520	4		24.60	51.20
500	20	645	30	24	600	20	22	M20	570	4		26.40	60.10
600	24	755	32	30	705	20	26	M24	670	5		34.80	103.00

## PN 10

Size		Bolting Details									Bore	Masses of flanges	
DN mm	Nominal Pipe Size inch	Outside Diam. of Flange A	Forged or Plate; Thickness of Flange Min. B1-Type01	Forged or Plate; Thickness of Flange Min. B2-Type05	Pitch Circle Diam. C	Number of Holes D	Diam. of Holes E	Diam. of Bolts Metric	Diam. of Raised Face F	Height of Raised Face G	Slip-On H	Type 01 (kg)	Type 05 (kg)
10	3/8	90	14	16	60	4	14	M12	40	2	BORE OF FLANGES TO SUIT EITHER PIPE OR TUBE OD - REFER PIPE & TUBE DIMENSIONS ON PAGES 36 & 37	0.60	0.72
15	1/2	95	14	16	65	4	14	M12	45	2		0.67	0.81
20	3/4	105	16	18	75	4	14	M12	58	2		0.94	1.14
25	1	115	16	18	85	4	14	M12	68	2		1.11	1.38
32	1-1/4	140	18	18	100	4	18	M16	78	2		1.82	2.03
40	1-1/2	150	18	18	110	4	18	M16	88	3		2.08	2.35
50	2	165	20	18	125	4	18	M16	102	3		2.73	2.88
65	2-1/2	185	20	18	145	8	18	M16	122	3		3.16	3.51
80	3	200	20	20	160	8	18	M16	138	3		3.60	4.61
100	4	220	22	20	180	8	18	M16	158	3		4.39	5.65
125	5	250	22	22	210	8	18	M16	188	3		5.41	8.13
150	6	285	24	22	240	8	22	M20	212	3		7.14	10.5
200	8	340	24	24	295	8	22	M20	268	3		9.27	16.5
250	10	395	26	26	350	12	22	M20	320	3		11.8	24.1
300	12	445	26	26	400	12	22	M20	370	4		13.6	30.8
350	14	505	30	26	460	16	22	M20	430	4		20.4	39.6
400	16	565	32	26	515	16	26	M24	482	4		27.5	49.4
450	18	615	36	28	565	20	26	M24	532	4		33.6	63.0
500	20	670	38	28	620	20	26	M24	585	4		40.2	75.2
600	24	780	42	34	725	20	30	M27	685	5		54.5	124

**Notes:**

1. All dimensions are in millimetres.
2. Only the Raised Face variant of each type of flange has been illustrated. Other variants available are Flat Face, Flat with O-Ring Groove or Spot-Faced and other flange facing types may change the "B" dimension, please contact your local Creative Piping Solutions office for more information.
3. For Threaded Flanges a Boss Flange is used to accommodate the thread. The Thread Form and Thread Type are not specified in the Standard, please contact your local Creative Piping Solutions office for more information.
4. All weights are approximates only.



## EN 1092-1 DIN FLANGES

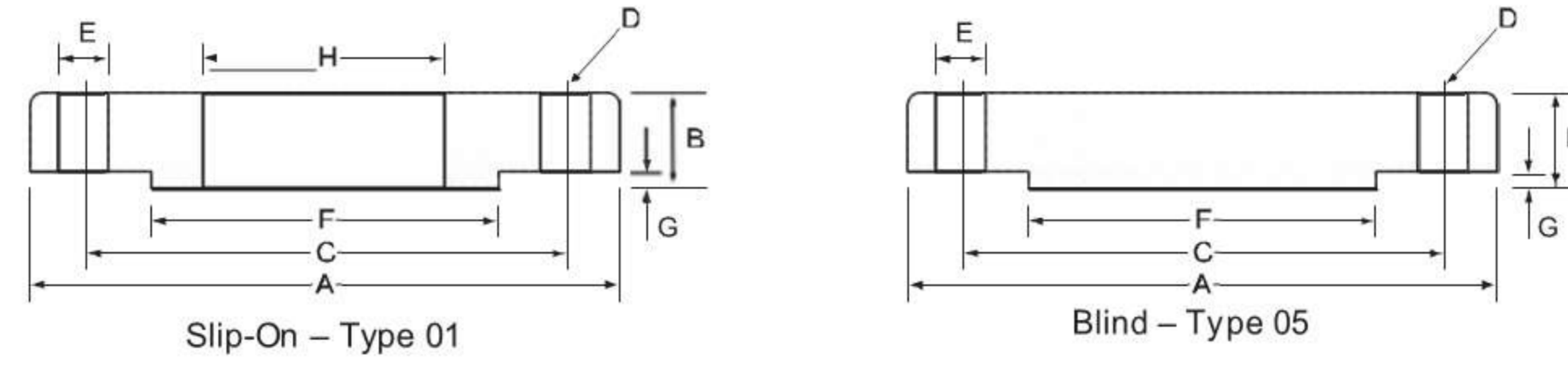

### PN 16

Size		Bolting Details									Bore	Masses of flanges	
DN mm	Nominal Pipe Size inch	Outside Diam. of Flange A	Forged or Plate; Thickness of Flange Min. B1-Type01	Forged or Plate; Thickness of Flange Min. B2-Type05	Pitch Circle Diam. C	Number of Holes D	Diam. of Holes E	Diam. of Bolts Metric	Diam. of Raised Face F	Height of Raised Face G	Slip-On H	Type 01 (kg)	PN 16 (kg)
10	3/8	90	14	16	60	4	14	M12	40	2	BORE OF FLANGES TO SUIT EITHER PIPE OR TUBE OD - REFER PIPE & TUBE DIMENSIONS ON PAGES 36 & 37	0.60	0.72
15	1/2	95	14	16	65	4	14	M12	45	2		0.67	0.81
20	3/4	105	16	18	75	4	14	M12	58	2		0.94	1.14
25	1	115	16	18	85	4	14	M12	68	2		1.11	1.38
32	1-1/4	140	18	18	100	4	18	M16	78	2		1.82	2.03
40	1-1/2	150	18	18	110	4	18	M16	88	3		2.08	2.35
50	2	165	20	18	125	4	18	M16	102	3		2.73	2.88
65	2-1/2	185	20	18	145	8	18	M16	122	3		3.16	3.51
80	3	200	20	20	160	8	18	M16	138	3		3.60	4.61
100	4	220	22	20	180	8	18	M16	158	3		4.39	5.65
125	5	250	22	22	210	8	18	M16	188	3		5.41	8.13
150	6	285	24	22	240	8	22	M20	212	3		7.14	10.5
200	8	340	26	24	295	12	22	M20	268	3		9.73	16.2
250	10	405	29	26	355	12	26	M24	320	3		14.2	25.0
300	12	460	32	28	410	12	26	M24	378	4		19.0	35.1
350	14	520	35	30	470	16	26	M24	438	4		28.2	48.0
400	16	580	38	32	525	16	30	M27	490	4		35.9	63.5
450	18	640	42	40	585	20	30	M27	550	4		46.1	96.6
500	20	715	46	44	650	20	33	M30	610	4	64.0	133	
600	24	840	55	54	770	20	36	M33	725	5	102	226	

### PN 25

Size		Bolting Details									Bore	Masses of flanges	
DN mm	Nominal Pipe Size inch	Outside Diam. of Flange A	Forged or Plate; Thickness of Flange Min. B1-Type01	Forged or Plate; Thickness of Flange Min. B2-Type05	Pitch Circle Diam. C	Number of Holes D	Diam. of Holes E	Diam. of Bolts Metric	Diam. of Raised Face F	Height of Raised Face G	Slip-On H	Type 01 (kg)	Type 05 (kg)
10	3/8	90	14	16	60	4	14	M12	40	2	BORE OF FLANGES TO SUIT EITHER PIPE OR TUBE OD - REFER PIPE & TUBE DIMENSIONS ON PAGES 36 & 37	0.60	0.72
15	1/2	95	14	16	65	4	14	M12	45	2		0.67	0.81
20	3/4	105	16	18	75	4	14	M12	58	2		0.94	1.14
25	1	115	16	18	85	4	14	M12	68	2		1.11	1.38
32	1-1/4	140	18	18	100	4	18	M16	78	2		1.82	2.03
40	1-1/2	150	18	18	110	4	18	M16	88	3		2.08	2.35
50	2	165	20	20	125	4	18	M16	102	3		2.73	3.20
65	2-1/2	185	22	22	145	8	18	M16	122	3		3.48	4.29
80	3	200	24	24	160	8	18	M16	138	3		4.32	5.54
100	4	235	26	24	190	8	22	M20	162	3		6.07	7.60
125	5	270	28	26	220	8	26	M24	188	3		8.19	10.8
150	6	300	30	28	250	8	26	M24	218	3		10.3	14.6
200	8	360	32	30	310	12	26	M24	278	3		14.3	22.5
250	10	425	35	32	370	12	30	M27	335	3		20.1	33.5
300	12	485	38	34	430	16	30	M27	395	4		26.6	46.3
350	14	555	42	38	490	16	33	M30	450	4		41.8	68.1
400	16	620	48	40	550	16	36	M33	505	4		57.6	89.7
450	18	670	54	50	600	20	36	M33	555	4		69.8	130
500	20	730	58	51	660	20	36	M33	615	4	87.0	159	
600	24	845	68	66	770	20	39	M36	720	5	127	278	

Notes:

- All dimensions are in millimetres.
- Only the Raised Face variant of each type of flange has been illustrated. Other variants available are Flat Face, Flat with O-Ring Groove or Spot-Faced and other flange facing types may change the "B" dimension, please contact your local Creative Piping Solutions office for more information.
- For Threaded Flanges a Boss Flange is used to accommodate the thread. The Thread Form and Thread Type are not specified in the Standard, please contact your local Creative Piping Solutions office for more information.
- All weights are approximates only.



# EN 1092-1 DIN FLANGES

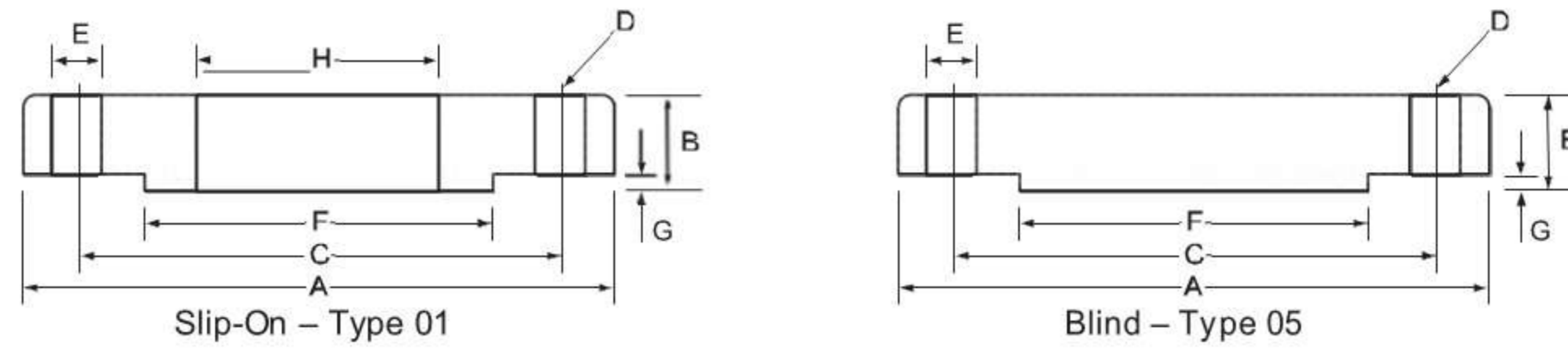

## PN 40

Size		Bolting Details									Bore	Masses of flanges	
DN mm	Nominal Pipe Size inch	Outside Diam. of Flange A	Forged or Plate; Thickness of Flange Min. B1-Type01	Forged or Plate; Thickness of Flange Min. B2-Type05	Pitch Circle Diam. C	Number of Holes D	Diam. of Holes E	Diam. of Bolts Metric	Diam. of Raised Face F	Height of Raised Face G	Slip-On H	Type 01 (kg)	Type 05 (kg)
10	3/8	90	14	16	60	4	14	M12	40	2	BORE OF FLANGES TO SUIT EITHER PIPE OR TUBE OD - REFER PIPE & TUBE DIMENSIONS ON PAGES 36 & 37	0.60	0.72
15	1/2	95	14	16	65	4	14	M12	45	2		0.67	0.81
20	3/4	105	16	18	75	4	14	M12	58	2		0.94	1.14
25	1	115	16	18	85	4	14	M12	68	2		1.11	1.38
32	1-1/4	140	18	18	100	4	18	M16	78	2		1.82	2.03
40	1-1/2	150	18	18	110	4	18	M16	88	3		2.08	2.35
50	2	165	20	20	125	4	18	M16	102	3		2.73	3.20
65	2-1/2	185	22	22	145	8	18	M16	122	3		3.48	4.29
80	3	200	24	24	160	8	18	M16	138	3		4.32	5.54
100	4	235	26	24	190	8	22	M20	162	3		6.07	7.60
125	5	270	28	26	220	8	26	M24	188	3		8.19	10.8
150	6	300	30	28	250	8	26	M24	218	3		10.3	14.6
200	8	375	36	36	320	12	30	M27	285	3		17.9	28.8
250	10	450	42	38	385	12	33	M30	345	3		29.3	44.4
300	12	515	52	42	450	16	33	M30	410	4		45.1	64.2
350	14	580	58	46	510	16	36	M33	465	4		66.7	89.5
400	16	660	65	50	585	16	39	M36	535	4		97.1	127
450	18	685		57	610	20	39	M36	560	4		-	154
500	20	755		57	670	20	42	M39	615	4		-	188
600	24	890		72	795	20	48	M45	735	5		-	331

**Notes:**

- All dimensions are in millimetres.
- Only the Raised Face variant of each type of flange has been illustrated. Other variants available are Flat Face, Flat with O-Ring Groove or Spot-Faced and other flange facing types may change the "B" dimension, please contact your local Creative Piping Solutions office for more information.
- For Threaded Flanges a Boss Flange is used to accommodate the thread. The Thread Form and Thread Type are not specified in the Standard, please contact your local Creative Piping Solutions office for more information.
- All weights are approximates only.

### TEMPERATURE/PRESSURE ratings for austenitic and austenitic-ferritic steels.

Max. allowable temperature TS °C	PN 6		PN 10		PN 16		PN 25		PN40	
	304	316	304	316	304	316	304	316	304	316
	304 L	316 L	304 L	316 L	304 L	316 L	304 L	316 L	304 L	316 L
<b>Max. allowable pressure PS bar</b>										
RT (-10 to 50)	6	6	10	10	16	16	25.0	25.0	40.0	40.0
100	5.1	6	8.6	10	13.7	16	21.5	25.0	34.4	40.0
150	4.6	5.4	7.7	9	12.3	14.5	19.2	22.7	30.8	36.3
200	4.2	5	7	8.4	11.2	13.4	17.5	21.0	28.0	33.7
250	3.9	4.7	6.5	7.9	10.4	12.7	16.3	19.8	26.0	31.8
300	3.6	4.4	6	7.4	9.6	11.8	15.1	18.5	24.1	29.7
350	3.4	4.2	5.7	7.1	9.2	11.4	14.4	17.8	23.0	28.5
400	3.3	4.1	5.5	6.8	8.8	10.9	13.8	17.1	22.0	27.4
450	3.2	4	5.3	6.7	8.5	10.7	13.3	16.8	21.4	26.9
500	3.1	3.9	5.1	6.6	8.3	10.5	12.9	16.5	20.7	26.4
550	2.6	3.9	4.3	6.5	7	10.4	10.9	16.3	17.5	26.0
560	2.4	3.8	4	6.4	6.4	10.3	10.1	16.0	16.1	25.7
570	2.2	3.8	3.7	6.3	5.9	10.1	9.2	15.8	14.8	25.4
580	2	3.7	3.4	6.2	5.4	10.0	8.5	15.6	13.7	25.0
590	1.8	3.7	3	6.1	4.9	9.9	7.7	15.4	12.3	24.7
600	1.6	3.3	2.8	5.6	4.4	8.9	7.0	14.0	11.2	22.4

**Note 1:** groupe 10E0 material based on ASME SA 240 and grades 304, 304 L, 304 H

**Note 2:** groupe 14E0 material based on ASME SA 240 and grades 316, 316 L, 316 H.



# AS 4087 WATER FLANGES

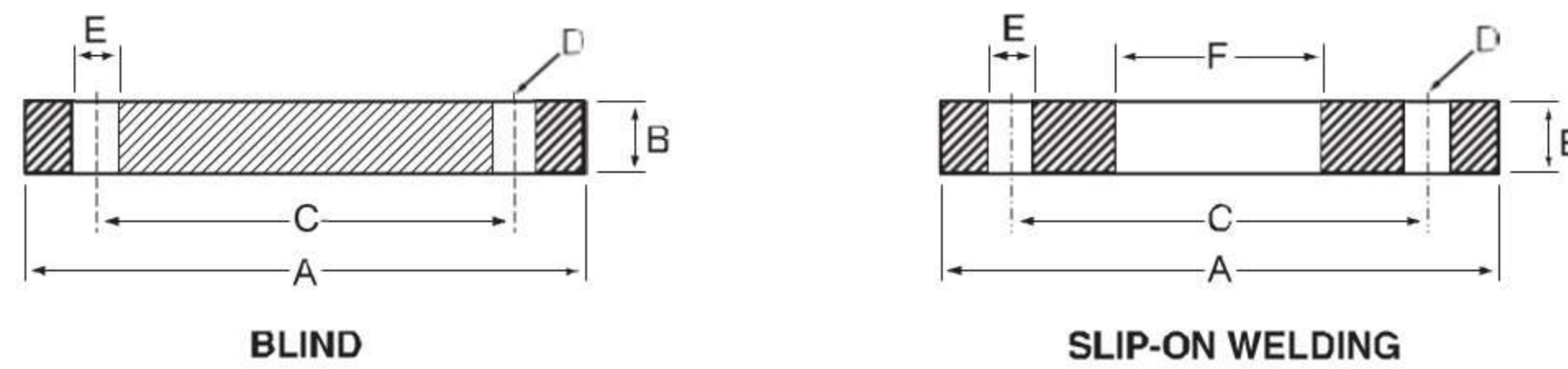

## PN 16

Size		Bolting Details						Bore	Masses of flanges	
DN mm	Nominal Pipe Size inch	Outside Diameter of Flange A	Forged or Plate; Thickness of Flange Min. B	Pitch Circle Diameter C	Number of Holes D	Diameter of Holes E	Diameter of Bolts Bolts Metric	Slip-On F	Blind (kg)	Slip-On (kg)
50	2	150	11	114	4	18	M16	BORE OF FLANGES TO SUIT PIPE OD - REFER PIPE DIMENSIONS ON PAGE 36	1.5	1.4
65	2-1/2	165	11	127	4	18	M16		1.8	1.7
80	3	185	11	146	4	18	M16		2.3	2.2
100	4	215	13	178	4	18	M16		3.7	3.5
150	6	280	13	235	8	18	M16		6.2	6.0
200	8	335	19	292	8	18	M16		13.1	12.7
225	9	370	19	324	8	18	M16		16.0	15.4
250	10	405	19	356	8	22	M20		19.1	18.2
300	12	455	23	406	12	22	M20		29.1	27.2
350	14	525	30	470	12	26	M24		50.4	46.7
375	15	550	30	495	12	26	M24		55.5	50.2
400	16	580	30	521	12	26	M24		61.9	52.8
450	18	640	30	584	12	26	M24		75.7	61.6
500	20	705	38	641	16	26	M24		116.1	91.0
600	24	825	48	756	16	30	M27		200.9	162.8

All dimensions are in millimetres.

## PN 21

Size		Bolting Details						Bore	Masses of flanges	
DN mm	Nominal Pipe Size inch	Outside Diameter of Flange A	Forged or Plate; Thickness of Flange Min. B	Pitch Circle Diameter C	Number of Holes D	Diameter of Holes E	Diameter of Bolts Bolts Metric	Slip-On F	Blind (kg)	Slip-On (kg)
50	2	165	15	127	4	18	M16	BORE OF FLANGES TO SUIT PIPE OD - REFER PIPE DIMENSIONS ON PAGE 36	2.4	2.4
65	2-1/2	185	15	146	8	18	M16		3.0	2.9
80	3	205	15	165	8	18	M16		3.7	3.6
100	4	230	19	191	8	18	M16		6.0	5.8
150	6	305	24	260	12	22	M20		13.2	12.8
200	8	370	24	324	12	22	M20		19.8	19.2
225	9	405	30	356	12	26	M24		29.4	28.4
250	10	430	30	381	12	26	M24		33.3	31.8
300	12	490	30	438	16	26	M24		43.2	40.8
350	14	550	30	495	16	30	M27		54.3	50.5
375	15	580	38	521	16	30	M27		76.9	70.1
400	16	610	38	552	20	30	M27		84.5	73.1
450	18	675	38	610	20	33	M30		103.6	85.8
500	20	735	48	673	24	33	M30		155.0	123.4
600	24	850	58	781	24	36	M33		252.0	205.9

All dimensions are in millimetres.



## AS 4087 WATER FLANGES

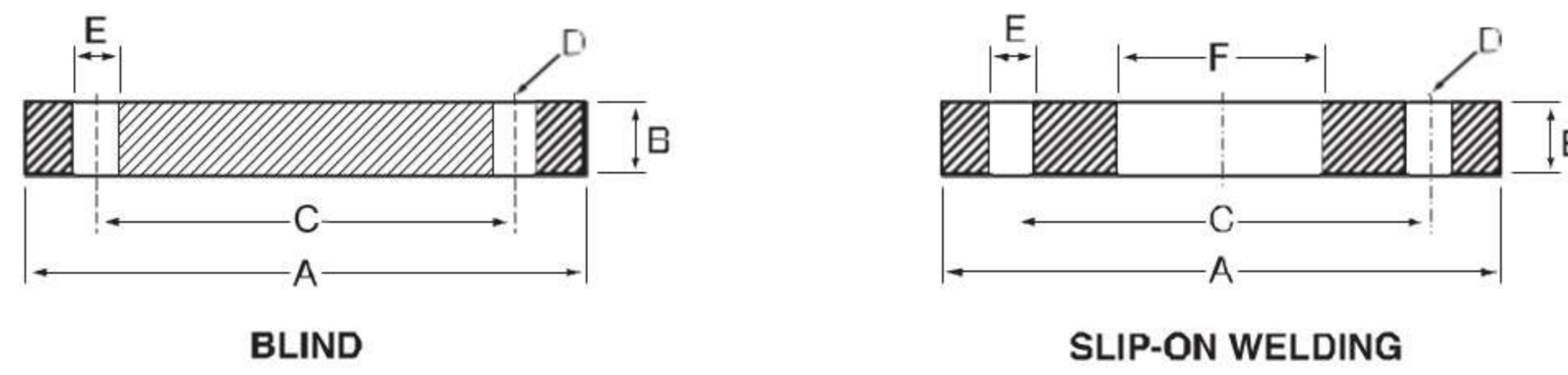

**PN 35**

Size		Bolting Details						Bore	Masses of flanges	
DN mm	Nominal Pipe Size inch	Outside Diameter of Flange A	Forged or Plate; Thickness of Flange Min. B	Pitch Circle Diameter C	Number of Holes D	Diameter of Holes E	Diameter of Bolts Bolts Metric	Slip-On F	Blind (kg)	Slip-On (kg)
50	2	165	19	127	4	18	M16	BORE OF FLANGES TO SUIT PIPE OD - REFER PIPE DIMENSIONS ON PAGE 36	3.1	3.0
65	2-1/2	185	19	146	8	18	M16		3.8	3.7
80	3	205	24	165	8	18	M16		5.9	5.8
100	4	230	24	191	8	18	M16		7.6	7.3
150	6	305	31	260	12	22	M20		17.0	16.5
200	8	370	31	324	12	22	M20		25.5	24.8
225	9	405	38	356	12	26	M24		37.2	36.0
250	10	430	38	381	12	26	M24		42.2	40.3
300	12	490	38	438	16	26	M24		54.7	51.6
350	14	550	48	495	16	30	M27		86.9	80.9
375	15	580	48	521	16	30	M27		97.1	88.6
400	16	610	48	552	20	30	M27		106.8	92.3
450	18	675	58	610	20	33	M30		158.1	130.9
500	20	735	58	673	24	33	M30		187.3	149.1
600	24	850	68	781	24	36	M33		295.4	241.4

All dimensions are in millimetres.

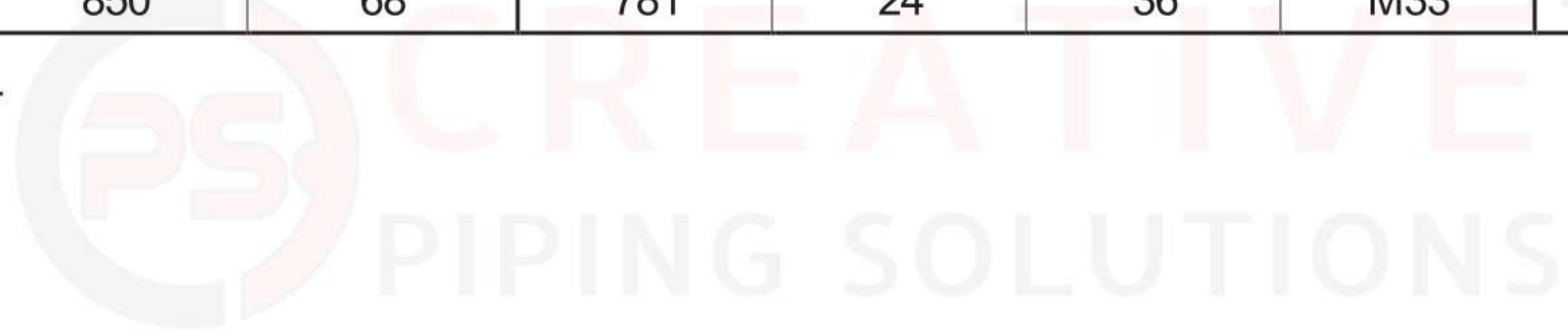

**ALLOWABLE PRESSURE TABLE FOR 316/316L and 304/304L DUAL GRADE FLANGES**

Pressure Class	AOP	MAOP	ASTP	MATTP
PN	kPa	kPa	kPa	kPa
16	1600	1920	2000	2400
21	2100	2520	2625	3150
35	3500	4200	4375	5250

**AOP** The allowable internal pressure, excluding surge, that a component can safely withstand in service.

**MAOP** Maximum internal pressure, including surge, that a component can safely withstand in service.

**ASTP** Maximum pressure applied on site in a newly installed pipeline (including a safety factor and allowances for surge).

**MATTP** The maximum allowable hydrostatic pressure applied to a flange for the purpose of proof or type testing an associated appurtenance.

The fluid contained by these flanges, is water, recycled water, sewerage or wastewater at temperatures not exceeding 80°C.



Size		Length Through Hub					Bore		Bolt Information													
DN mm	Nominal Pipe Size inch	Outside Diameter of Flange O	Thickness of Flange Min. C	Thickness of Lap Joint Min. C	Diameter of Hub X	Hub Diameter Beginning of Chamfer Welding Neck A	Threaded/ Slip-On/ Socket Welding Y	Lapped Y	Welding Neck Y	Slip-On/ Socket Welding Min. B	Lapped Min. B	Welding Neck/ Socket Welding B1	Diameter of Raised Face R	Height of Raised Face f	Corner Radius of Bore of Lapped Flange and Pipe r	Depth of Socket D	Diameter of Bolt Circle	Diameter of Bolt Holes	Number of Bolts	Diameter of Bolts (inch)	Length of Stud Bolts 1.6mm Raised Face	Length of Machine Bolts 1.6mm Raised Face
15	1/2	88.9	9.7	11.2	30.2	21.3	14.2	15.7	46.0	22.4	22.9	To be specified by the purchaser	35.1	1.6	3.0	9.7	60.5	15.9	4	1/2	57.2	50.8
20	3/4	98.6	11.2	12.7	38.1	26.7	14.2	15.7	50.8	27.7	28.2		42.9	1.6	3.0	11.2	69.9	15.9	4	1/2	63.5	50.8
25	1	108.0	12.7	14.2	49.3	33.5	15.7	17.5	53.8	34.5	35.1		50.8	1.6	3.0	12.7	79.2	15.9	4	1/2	63.5	57.2
32	1-1/4	117.3	14.2	15.7	58.7	42.2	19.1	20.6	55.6	43.2	43.7		63.5	1.6	4.8	14.2	88.9	15.9	4	1/2	69.9	57.2
40	1-1/2	127.0	15.7	17.5	65.0	48.3	20.6	22.4	60.5	49.5	50.0		73.2	1.6	6.4	15.7	98.6	15.9	4	1/2	69.9	63.5
50	2	152.4	17.5	19.1	77.7	60.5	23.9	25.4	62.0	62.0	62.5		91.9	1.6	7.9	17.5	120.7	19.1	4	5/8	82.6	69.9
65	2-1/2	177.8	20.6	22.4	90.4	73.2	26.9	28.4	68.3	74.7	75.4		104.6	1.6	7.9	19.1	139.7	19.1	4	5/8	88.9	76.2
80	3	190.5	22.4	23.9	108.0	88.9	28.4	30.2	68.3	90.7	91.4		127.0	1.6	9.7	20.6	152.4	19.1	4	5/8	88.9	76.2
90	3-1/2	215.9	22.4	23.9	122.2	101.6	30.2	31.8	69.9	103.4	104.1		139.7	1.6	9.7		177.8	19.1	8	5/8	88.9	76.2
100	4	228.6	22.4	23.9	134.9	114.3	31.8	33.3	74.7	116.1	116.8		157.2	1.6	11.2		190.5	19.1	8	5/8	88.9	76.2
125	5	254.0	22.4	23.9	163.6	141.2	35.1	36.6	87.4	143.8	144.5		185.7	1.6	11.2		215.9	22.2	8	3/4	95.3	82.6
150	6	279.4	23.9	25.4	192.0	168.4	38.1	39.6	87.4	170.7	171.5		215.9	1.6	12.7		241.3	22.2	8	3/4	101.6	82.6
200	8	342.9	26.9	28.4	246.1	219.2	42.9	44.5	100.1	221.5	222.3		269.7	1.6	12.7		298.5	22.2	8	3/4	108.0	88.9
250	10	406.4	28.4	30.2	304.8	273.1	47.8	49.3	100.1	276.4	277.4		323.9	1.6	12.7		362.0	25.4	12	7/8	114.3	101.6
300	12	482.6	30.2	31.8	365.3	323.9	53.8	55.6	112.8	327.2	328.2		381.0	1.6	12.7		431.8	25.4	12	7/8	120.7	101.6
350	14	533.4	33.3	35.1	400.1	355.6	55.6	79.2	125.5	359.2	360.2		412.8	1.6	12.7		476.3	28.6	12	1	133.4	114.3
400	16	596.9	35.1	36.6	457.2	406.4	62.0	87.4	125.5	410.5	411.2		469.9	1.6	12.7		539.8	28.6	16	1	133.4	114.3
450	18	635.0	38.1	39.6	505.0	457.2	66.5	96.8	138.2	461.8	462.3		533.4	1.6	12.7		577.9	31.8	16	1-1/8	146.1	127.0
500	20	698.5	41.1	42.9	558.8	508.0	71.4	103.1	142.7	513.1	514.4		584.2	1.6	12.7		635.0	31.8	20	1-1/8	158.8	139.7
600	24	812.8	46.0	47.8	663.4	609.6	81.0	111.3	150.9	616.0	616.0		692.2	1.6	12.7		749.3	34.9	20	1-1/4	171.5	152.4

Size		Approximate piece weight in Kilograms					
DN	NPS	Blind	Weld Neck	Slip-On	Lap Joint	Socket Weld	Threaded
15	1/2	0.47	0.51	0.47	0.51	0.47	0.47
20	3/4	0.63	0.73	0.58	0.64	0.59	0.58
25	1	0.94	1.07	0.86	0.93	0.87	0.86
32	1-1/4	1.23	1.40	1.08	1.16	1.11	1.08
40	1-1/2	1.62	1.81	1.41	1.51	1.45	1.41
50	2	2.64	2.59	2.26	2.38	2.33	2.26
65	2-1/2	4.06	4.28	3.43	3.60	3.55	3.43
80	3	4.90	5.18	3.87	4.04	4.02	3.87
90	3-1/2	5.90	5.45	4.99	4.99		4.99
100	4	7.41	7.32	5.75	5.96		5.75
125	5	8.76	8.91	6.22	6.44		6.22
150	6	11.31	11.26	7.38	7.59		7.38
200	8	19.92	17.68	12.36	12.66		12.36
250	10	29.39	24.79	17.10	16.78		17.10
300	12	43.70	38.98	27.68	28.30		27.68
350	14	59.42	51.71	35.20	41.50		35.20
400	16	77.11	64.41	42.18	52.98		42.18
450	18	94.80	74.84	49.71	59.00		49.71
500	20	123.38	89.36	65.50	72.12		65.50
600	24	188.24	119.66	90.50	99.02		90.50

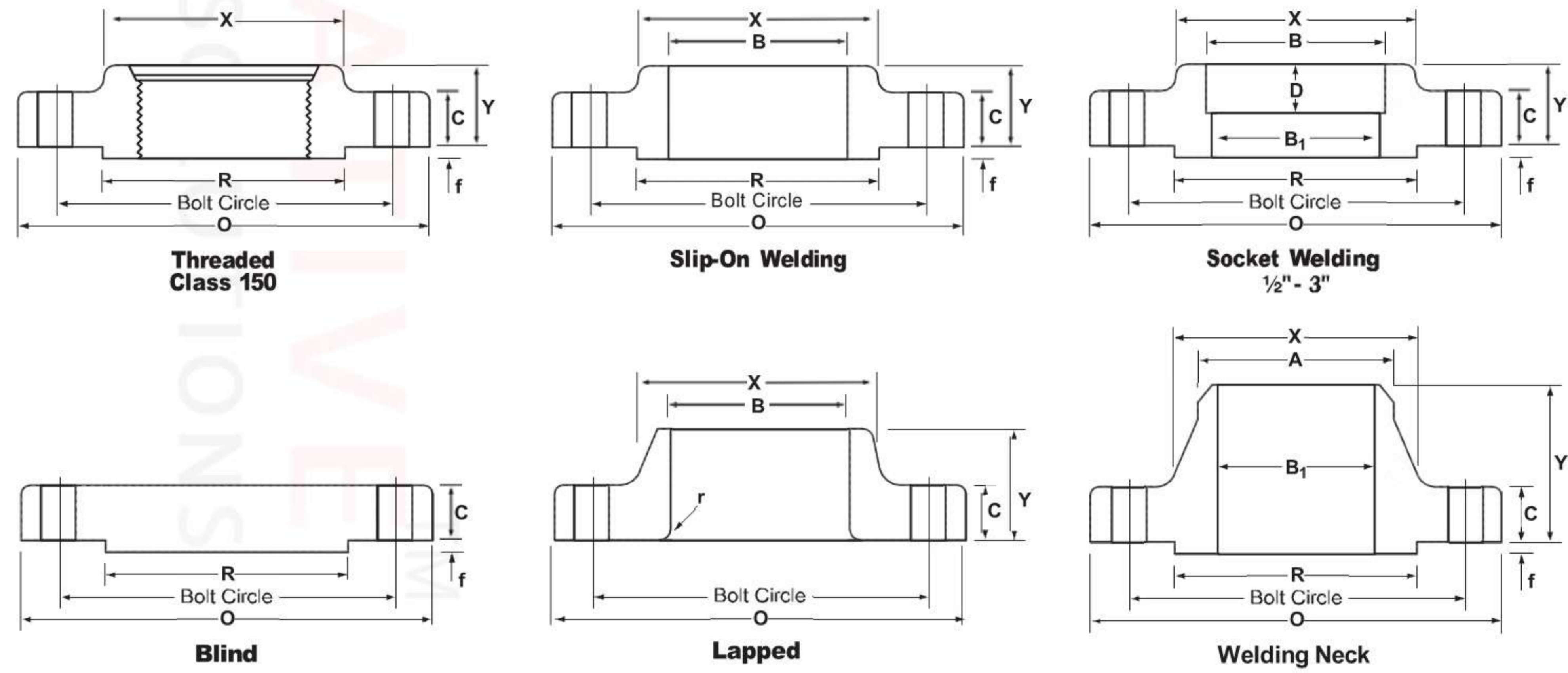

**Notes:**

1. Flange Raised Face Diameter and Height are based on a standard Raised Face, other flange facing types will change the "R" and "f" dimensions
2. For Threaded Flanges in this Class a counterbore is not required.
3. All dimensions are converted from the ASME B16.5 inch system to millimetres using 1" = 25.4 mm and rounded to one decimal point, except where noted.
4. All weights are approximate only.

**ANSI CLASS 150**



ANSI CLASS 300

Size		Length Through Hub					Bore					Bolt Information											
DN mm	Nominal Pipe Size inch	Outside Diameter of Flange O	Thickness of Flange Min. C	Thickness of Lap Joint Min. C	Diameter of Hub X	Hub Diameter Beginning of Chamfer Welding Neck A	Threaded/ Slip-On/ Socket Welding Y	Lapped Y	Welding Neck Y	Slip-On/ Socket Welding Min. B	Lapped Min. B	Welding Neck/ Socket Welding B1	Diameter of Raised Face R	Height of Raised Face f	Corner Radius of Bore of Lapped Flange and Pipe r	Depth of Socket D	Counter-bore Diameter Threaded Flange Min. Q	Diameter of Bolt Circle	Diameter of Bolt Holes	Number of Bolts	Diameter of Bolts (inch)	Length of Stud Bolts 1.6mm Raised Face	Length of Machine Bolts 1.6mm Raised Face
15	1/2	95.3	12.7	14.2	38.1	21.3	20.6	22.4	50.8	22.4	22.9	To be specified by the purchaser	35.1	1.6	3.0	23.6	9.7	66.5	15.9	4	1/2	63.5	57.2
20	3/4	117.3	14.2	15.7	47.8	26.7	23.9	25.4	55.6	27.7	28.2		42.9	1.6	3.0	29.0	11.2	82.6	19.1	4	5/8	76.2	63.5
25	1	124.0	15.7	17.5	53.8	33.5	25.4	26.9	60.5	34.5	35.1		50.8	1.6	3.0	35.8	12.7	88.9	19.1	4	5/8	76.2	63.5
32	1-1/4	133.4	17.5	19.1	63.5	42.2	25.4	26.9	63.5	43.2	43.7		63.5	1.6	4.8	44.5	14.2	98.6	19.1	4	5/8	82.6	69.9
40	1-1/2	155.4	19.1	20.6	69.9	48.3	28.7	30.2	66.8	49.5	50.0		73.2	1.6	6.4	50.3	15.7	114.3	22.2	4	3/4	88.9	76.2
50	2	165.1	20.6	22.4	84.1	60.5	31.8	33.3	68.3	62.0	62.5		91.9	1.6	7.9	63.5	17.5	127.0	19.1	8	5/8	88.9	76.2
65	2-1/2	190.5	23.9	25.4	100.1	73.2	36.6	38.1	74.7	74.7	75.4		104.6	1.6	7.9	76.2	19.1	149.4	22.2	8	3/4	101.6	82.6
80	3	209.6	26.9	28.4	117.3	88.9	41.4	42.9	77.7	90.7	91.4		127.0	1.6	9.7	92.2	20.6	168.1	22.2	8	3/4	108.0	88.9
90	3-1/2	228.6	28.4	30.2	133.4	101.6	42.9	44.5	79.5	103.4	104.1		139.7	1.6	9.7	104.9		184.2	22.2	8	3/4	108.0	95.3
100	4	254.0	30.2	31.8	146.1	114.3	46.2	47.8	84.3	116.1	116.8		157.2	1.6	11.2	117.6		200.2	22.2	8	3/4	114.3	95.3
125	5	279.4	33.3	35.1	177.8	141.2	49.3	50.8	97.0	143.8	144.5		185.7	1.6	11.2	144.5		235.0	22.2	8	3/4	120.7	108.0
150	6	317.5	35.1	36.6	206.2	168.4	50.8	52.3	97.0	170.7	171.5		215.9	1.6	12.7	171.5		269.7	22.2	12	3/4	120.7	108.0
200	8	381.0	39.6	41.1	260.4	219.2	60.5	62.0	109.7	221.5	222.3		269.7	1.6	12.7	222.3		330.2	25.4	12	7/8	139.7	120.7
250	10	444.5	46.0	47.8	320.5	273.1	65.0	95.3	115.8	276.4	277.4		323.9	1.6	12.7	276.4		387.4	28.6	16	1	158.8	139.7
300	12	520.7	49.3	50.8	374.7	323.9	71.6	101.6	128.5	327.2	328.2		381.0	1.6	12.7	328.7		450.9	31.8	16	1-1/8	171.5	146.1
350	14	584.2	52.3	53.8	425.5	355.6	74.7	111.3	141.2	359.2	360.2		412.8	1.6	12.7	360.4		514.4	31.8	20	1-1/8	177.8	158.8
400	16	647.7	55.6	57.2	482.6	406.4	81.0	120.7	144.5	410.5	411.2		469.9	1.6	12.7	411.2		571.5	34.9	20	1-1/4	190.5	165.1
450	18	711.2	58.7	60.5	533.4	457.2	87.4	130.0	157.2	461.8	462.3		533.4	1.6	12.7	462.0		628.7	34.9	24	1-1/4	196.9	171.5
500	20	774.7	62.0	63.5	587.2	508.0	93.7	139.7	160.5	513.1	514.4		584.2	1.6	12.7	512.8		685.8	34.9	24	1-1/4	203.2	184.2
600	24	914.4	68.3	69.9	701.5	609.6	104.9	152.4	166.6	616.0	616.0		692.2	1.6	12.7	614.4		812.8	41.3	24	1-1/2	228.6	203.2

Size		Approximate piece weight in Kilograms					
DN	NPS	Blind	Weld Neck	Slip-On	Lap Joint	Socket Weld	Threaded
15	1/2	0.62	0.78	0.62	0.61	0.62	0.62
20	3/4	1.16	1.34	1.15	1.15	1.19	1.15
25	1	1.42	1.64	1.39	1.38	1.44	1.39
32	1-1/4	1.79	2.06	1.67	1.66	1.73	1.67
40	1-1/2	2.68	3.06	2.53	2.52	2.62	2.53
50	2	3.09	3.40	2.80	2.79	2.94	2.80
65	2-1/2	4.75	5.31	4.25	4.22	4.49	4.25
80	3	6.79	7.32	5.81	5.78	6.20	5.81
90	3-1/2	9.53	8.17	7.72	7.72		7.72
100	4	12.00	11.30	10.13	10.07		10.13
125	5	15.96	15.12	12.58	12.52		12.58
150	6	21.20	19.68	16.04	15.95		16.04
200	8	34.60	30.48	24.50	24.37		24.50
250	10	55.34	43.74	34.16	39.92		34.16
300	12	78.90	64.41	51.26	58.70		51.26
350	14	107.05	88.30	72.12	83.46		72.12
400	16	139.25	112.94	90.40	106.14		90.40
450	18	176.90	138.34	109.00	133.95		109.00
500	20	223.17	167.37	136.00	157.65		136.00
600	24	342.00	235.41	204.00	240.40		204.00

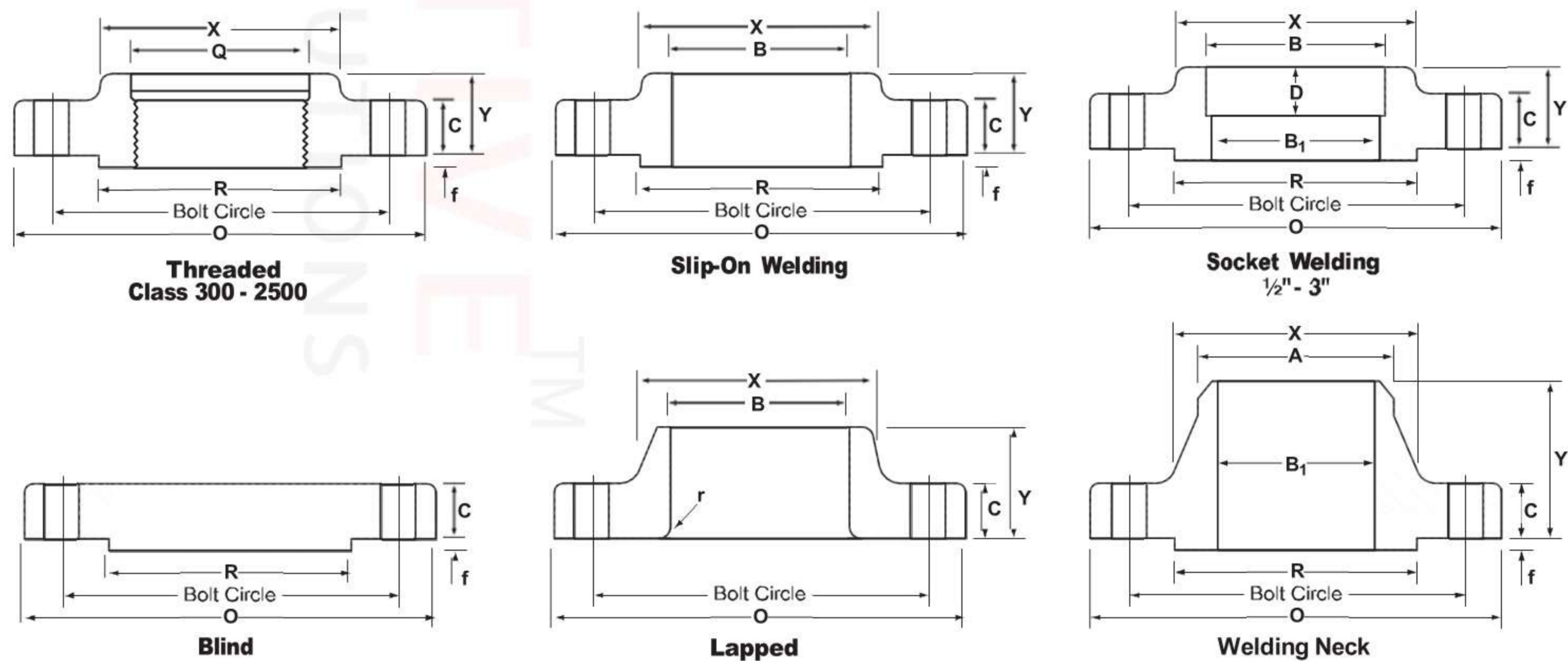

Notes:

1. Flange Raised Face Diameter and Height are based on a standard Raised Face, other flange facing types will change the "R" and "f" dimensions
2. For Threaded Flanges in this Class a counterbore is required. NPS Sizes 50 and smaller will have a 6.4 counterbore and NPS sizes 65 and larger will have a 9.5 counterbore.
3. All dimensions are converted from the ASME B16.5 inch system to millimetres using 1" = 25.4 mm and rounded to one decimal point, except where noted.
4. All weights are approximate only.



Size		Length Through Hub				Bore		Bolt Information													
DN mm	Nominal Pipe Size inch	Outside Diameter of Flange O	Thickness of Flange Min. C	Diameter of Hub X	Hub Diameter Beginning of Chamfer Welding Neck A	Threaded/ Slip-On/ Socket Welding Y	Lapped Y	Welding Neck Y	Slip-On/ Socket Welding Min. B	Lapped Min. B	Welding Neck/ Socket Welding B1	Diameter of Raised Face R	Height of Raised Face f	Corner Radius of Bore of Lapped Flange and Pipe r	Counter-bore Diameter Threaded Flange Min. Q	Depth of Socket D	Diameter of Bolt Circle	Diameter of Bolt Holes	Number of Bolts	Diameter of Bolts (inch)	Length of Stud Bolts 6.4mm Raised Face
15	1/2	95.3	14.2	38.1	21.3	22.4	22.4	52.3	22.4	22.9	To be specified by the purchaser	35.1	6.4	3.0	23.6	9.7	66.5	15.9	4	1/2	76.2
20	3/4	117.3	15.7	47.8	26.7	25.4	25.4	57.2	27.7	28.2		42.9	6.4	3.0	29.0	11.2	82.6	19.1	4	5/8	88.9
25	1	124.0	17.5	53.8	33.5	26.9	26.9	62.0	34.5	35.1		50.8	6.4	3.0	35.8	12.7	88.9	19.1	4	5/8	88.9
32	1-1/4	133.4	20.6	63.5	42.2	28.4	28.4	66.5	43.2	43.7		63.5	6.4	4.8	44.5	14.2	98.6	19.1	4	5/8	95.3
40	1-1/2	155.4	22.4	69.9	48.3	31.8	31.8	69.9	49.5	50.0		73.2	6.4	6.4	50.5	15.7	114.3	22.2	4	3/4	108.0
50	2	165.1	25.4	84.1	60.5	36.6	36.6	73.2	62.0	62.5		91.9	6.4	7.9	63.5	17.5	127.0	19.1	8	5/8	108.0
65	2-1/2	190.5	28.4	100.1	73.2	41.1	41.1	79.2	74.7	75.4		104.6	6.4	7.9	76.2	19.1	149.4	22.2	8	3/4	120.7
80	3	209.6	31.8	117.3	88.9	46.0	46.0	82.6	90.7	91.4		127.0	6.4	9.7	92.2	20.6	168.1	22.2	8	3/4	127.0
90	3-1/2	228.6	35.1	133.4	101.6	49.3	49.3	85.9	103.4	104.1		139.7	6.4	9.7	104.9		184.2	25.4	8	7/8	139.7
100	4	273.1	38.1	152.4	114.3	53.8	53.8	101.6	116.1	116.8		157.2	6.4	11.2	117.6		215.9	25.4	8	7/8	146.1
125	5	330.2	44.5	189.0	141.2	60.5	60.5	114.3	143.8	144.5		185.7	6.4	11.2	144.5		266.7	28.6	8	1	165.1
150	6	355.6	47.8	222.3	168.4	66.5	66.5	117.3	170.7	171.5		215.9	6.4	12.7	171.5		292.1	28.6	12	1	171.5
200	8	419.1	55.6	273.1	219.2	76.2	76.2	133.4	221.5	222.3		269.7	6.4	12.7	222.3		349.3	31.8	12	1-1/8	190.5
250	10	508.0	63.5	342.9	273.1	85.9	111.3	152.4	276.4	277.4		323.9	6.4	12.7	276.4		431.8	34.9	16	1-1/4	215.9
300	12	558.8	66.5	400.1	323.9	91.9	117.3	155.4	327.2	328.2		381.0	6.4	12.7	328.7		489.0	34.9	20	1-1/4	222.3
350	14	603.3	69.9	431.8	355.6	93.7	127.0	165.1	359.2	360.2		412.8	6.4	12.7	360.4		527.1	38.1	20	1-3/8	235.0
400	16	685.8	76.2	495.3	406.4	106.4	139.7	177.8	410.5	411.2		469.9	6.4	12.7	411.2		603.3	41.3	20	1-1/2	254.0
450	18	743.0	82.6	546.1	457.2	117.3	152.4	184.2	461.8	462.3		533.4	6.4	12.7	462.0		654.1	44.5	20	1-5/8	273.1
500	20	812.8	88.9	609.6	508.0	127.0	165.1	190.5	513.1	514.4		584.2	6.4	12.7	512.8		723.9	44.5	24	1-5/8	285.8
600	24	939.8	101.6	717.6	609.6	139.7	184.2	203.2	616.0	616.0		692.2	6.4	12.7	614.4		838.2	50.8	24	1-7/8	330.2

Size		Approximate piece weight in Kilograms					
DN	NPS	Blind	Weld Neck	Slip-On	Lap Joint	Socket Weld	Threaded
15	1/2	0.91	0.90	0.91	0.80	0.91	0.91
20	3/4	1.40	1.59	1.40	1.36	1.36	1.40
25	1	1.81	1.90	1.70	1.59	1.81	1.70
32	1-1/4	2.40	2.49	2.27	2.04	2.60	2.27
40	1-1/2	3.40	3.63	3.10	2.96	3.18	3.10
50	2	4.40	4.54	3.63	3.63	3.90	3.63
65	2-1/2	6.80	6.35	5.44	4.99	5.90	5.44
80	3	8.90	8.10	7.26	6.35	7.40	7.26
90	3-1/2	13.17	11.80	9.53	9.08		9.53
100	4	18.60	16.78	14.97	14.06		14.97
125	5	30.84	30.87	28.50	27.50		28.50
150	6	38.00	36.77	36.32	35.38		36.32
200	8	62.20	50.80	44.00	50.80		44.00
250	10	102.00	86.26	76.20	74.00		76.20
300	12	132.00	102.51	97.52	108.56		97.52
350	14	158.00	121.56	102.00	111.00		102.00
400	16	224.73	177.06	149.82	165.71		149.82
450	18	285.00	215.65	180.10	194.00		180.10
500	20	365.00	267.86	231.54	258.78		231.54
600	24	533.45	372.00	330.00	362.00		330.00

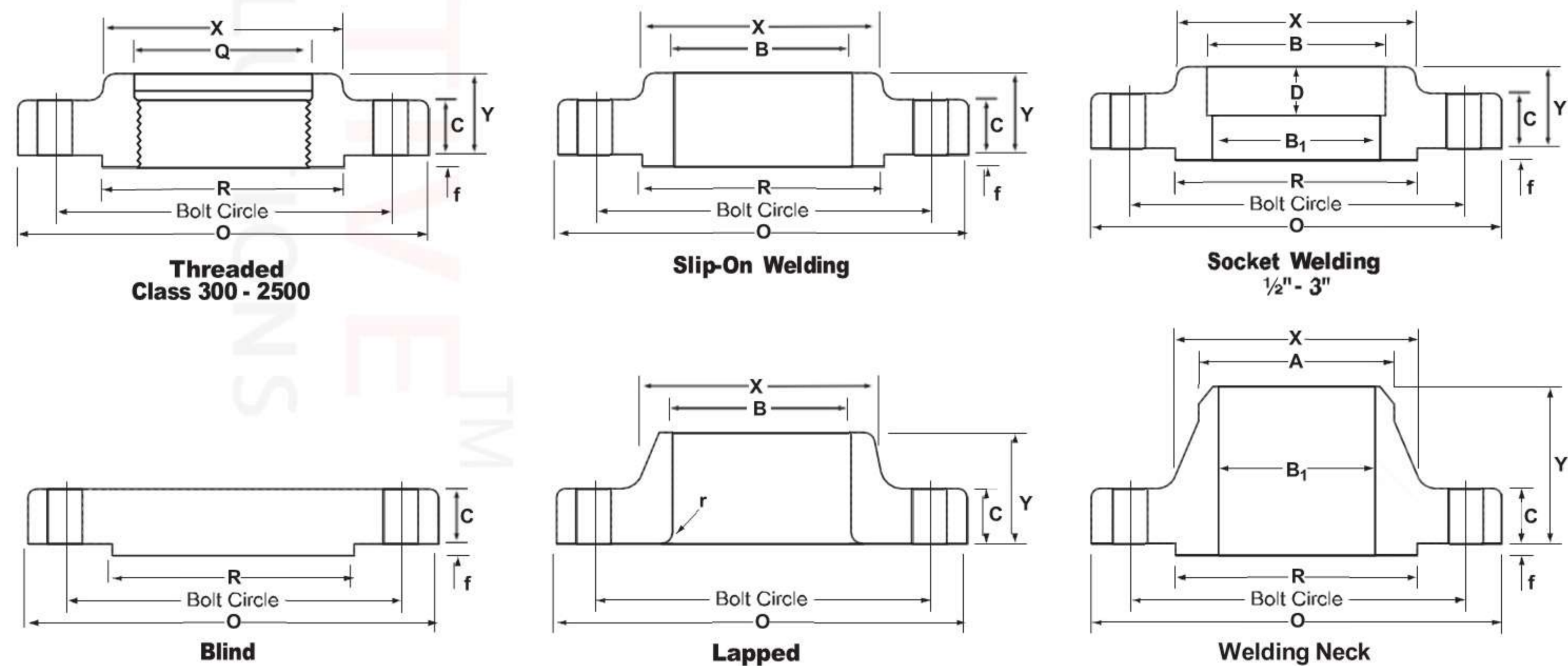

**Notes:**

1. Flange Raised Face Diameter and Height are based on a standard Raised Face, other flange facing types will change the "R" and "f" dimensions
2. For Threaded Flanges in this Class a counterbore is required. NPS Sizes 50 and smaller will have a 6.4 counterbore and NPS sizes 65 and larger will have a 9.5 counterbore.
3. All dimensions are converted from the ASME B16.5 inch system to millimetres using 1" = 25.4 mm and rounded to one decimal point, except where noted.
4. All weights are approximate only.

**ANSI CLASS 600**



ANSI CLASS 900

Size		Length Through Hub				Bore					Bolt Information										
DN mm	Nominal Pipe Size inch	Outside Diameter of Flange O	Thickness of Flange Min. C	Diameter of Hub X	Hub Diameter Beginning of Chamfer Welding Neck A	Threaded/ Slip-On/ Socket Welding Y	Lapped Y	Welding Neck Y	Slip-On/ Socket Welding Min. B	Lapped Min. B	Welding Neck B1	Diameter of Raised Face R	Height of Raised Face f	Corner Radius of Bore of Lapped Flange and Pipe r	Counter-bore Diameter Threaded Flange Min. Q	Depth of Socket D	Diameter of Bolt Circle	Diameter of Bolt Holes	Number of Bolts	Diameter of Bolts (inch)	Length of Stud Bolts 6.4mm Raised Face
15	1/2	120.7	22.4	38.1	21.3	31.8	31.8	60.5	22.4	22.9	To be specified by the purchaser	35.1	6.4	3.0	23.6	9.7	82.6	22.2	4	3/4	108.0
20	3/4	130.0	25.4	44.5	26.7	35.1	35.1	69.9	27.7	28.2		42.9	6.4	3.0	29.0	11.2	88.9	22.2	4	3/4	114.3
25	1	149.4	28.4	52.3	33.5	41.1	41.1	73.2	34.5	35.1		50.8	6.4	3.0	35.8	12.7	101.6	25.4	4	7/8	127.0
32	1-1/4	158.8	28.4	63.5	42.2	41.1	41.1	73.2	43.2	43.7		63.5	6.4	4.8	44.5	14.2	111.3	25.4	4	7/8	127.0
40	1-1/2	177.8	31.8	69.9	48.3	44.5	44.5	82.6	49.5	50.0		73.2	6.4	6.4	50.5	15.7	124.0	28.6	4	1	139.7
50	2	215.9	38.1	104.6	60.5	57.2	57.2	101.6	62.0	62.5		91.9	6.4	7.9	63.5	17.5	165.1	25.4	8	7/8	146.1
65	2-1/2	244.3	41.1	124.0	73.2	63.5	63.5	104.6	74.7	75.4		104.6	6.4	7.9	76.2	19.1	190.5	28.6	8	1	158.8
80	3	241.3	38.1	127.0	88.9	53.8	53.8	101.6	90.7	91.4		127.0	6.4	9.7	92.2		190.5	25.4	8	7/8	146.1
100	4	292.1	44.5	158.8	114.3	69.9	69.9	114.3	116.1	116.8		157.2	6.4	11.2	117.6		235.0	31.8	8	1-1/8	171.5
125	5	349.3	50.8	190.5	141.2	79.2	79.2	127.0	143.8	144.5		185.7	6.4	11.2	144.5		279.4	34.9	8	1-1/4	190.5
150	6	381.0	55.6	235.0	168.4	85.9	85.9	139.7	170.7	171.5		215.9	6.4	12.7	171.5		317.5	31.8	12	1-1/8	190.5
200	8	469.9	63.5	298.5	219.2	101.6	114.3	162.1	221.5	222.3		269.7	6.4	12.7	222.3		393.7	38.1	12	1-3/8	222.3
250	10	546.1	69.9	368.3	273.1	108.0	127.0	184.2	276.4	277.4		323.9	6.4	12.7	276.4		469.9	38.1	16	1-3/8	235.0
300	12	609.6	79.2	419.1	323.9	117.3	142.7	200.2	327.2	328.2		381.0	6.4	12.7	328.7		533.4	38.1	20	1-3/8	254.0
350	14	641.4	85.9	450.9	355.6	130.0	155.4	212.9	359.2	360.2		412.8	6.4	12.7	360.4		558.8	41.3	20	1-1/2	273.1
400	16	704.9	88.9	508.0	406.4	133.4	165.1	215.9	410.5	411.2		469.9	6.4	12.7	411.2		616.0	44.5	20	1-5/8	285.8
450	18	787.4	101.6	565.2	457.2	152.4	190.5	228.6	461.8	462.3		533.4	6.4	12.7	462.0		685.8	50.8	20	1-7/8	323.9
500	20	857.3	108.0	622.3	508.0	158.8	209.6	247.7	513.1	514.4		584.2	6.4	12.7	512.8		749.3	54.0	20	2	349.3
600	24	1041.4	139.7	749.3	609.6	203.2	266.7	292.1	616.0	616.0		692.2	6.4	12.7	614.4		901.7	66.7	20	2-1/2	438.2

Size		Approximate piece weight in Kilograms					
DN	NPS	Blind	Weld Neck	Slip-On	Lap Joint	Socket Weld	Threaded
15	1/2	1.90	2.10	1.80	1.80	1.81	1.80
20	3/4	2.72	2.72	2.27	2.27	2.81	2.27
25	1	4.08	3.86	3.40	3.40	3.61	3.40
32	1-1/4	4.30	4.54	4.10	4.09	4.99	4.10
40	1-1/2	5.90	5.90	5.45	5.40	6.76	5.45
50	2	11.30	10.89	10.50	9.53	10.89	10.50
65	2-1/2	16.00	16.34	15.80	13.15	16.34	15.80
80	3	13.17	15.00	11.80	11.34		11.80
100	4	24.50	23.13	23.20	22.60		23.20
125	5	39.46	38.50	37.65	36.74		37.65
150	6	51.50	49.89	48.30	47.50		48.30
200	8	89.00	79.45	75.00	86.00		75.00
250	10	131.54	118.04	111.13	125.64		111.13
300	12	187.00	157.00	146.00	167.00		146.00
350	14	224.07	181.60	172.36	180.07		172.36
400	16	272.40	224.73	192.95	211.11		192.95
450	18	385.90	308.72	272.40	295.10		272.40
500	20	488.00	376.82	331.42	367.74		331.42
600	24	905.00	685.00	632.00	700.00		632.00

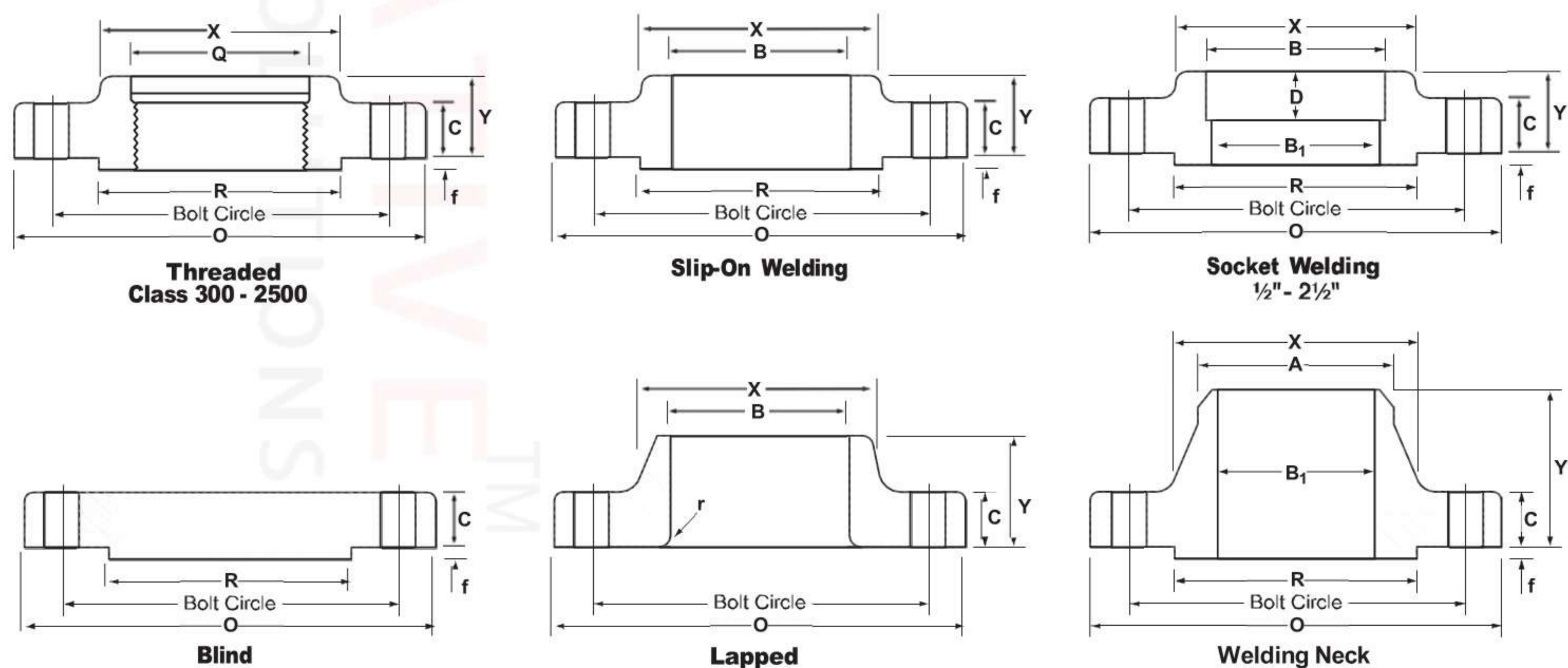

Notes:

1. Flange Raised Face Diameter and Height are based on a standard Raised Face, other flange facing types will change the "R" and "f" dimensions
2. For Threaded Flanges in this Class a counterbore is required. NPS Sizes 50 and smaller will have a 6.4 counterbore and NPS sizes 65 and larger will have a 9.5 counterbore.
3. All dimensions are converted from the ASME B16.5 inch system to millimetres using 1" = 25.4 mm and rounded to one decimal point, except where noted.
4. All weights are approximate only.



Size		Length Through Hub				Bore		Bolt Information													
DN mm	Nominal Pipe Size inch	Outside Diameter of Flange O	Thickness of Flange Min. C	Diameter of Hub X	Hub Diameter Beginning of Chamfer Welding Neck A	Threaded/ Slip-On/ Socket Welding Y	Lapped Y	Welding Neck Y	Slip-On/ Socket Welding Min. B	Lapped Min. B	Welding Neck/ Socket Welding B1	Diameter of Raised Face R	Height of Raised Face f	Corner Radius of Bore of Lapped Flange and Pipe r	Counter-bore Diameter Threaded Flange Min. Q	Depth of Socket D	Diameter of Bolt Circle	Diameter of Bolt Holes	Number of Bolts	Diameter of Bolts (inch)	Length of Stud Bolts 6.4mm Raised Face
15	1/2	120.7	22.4	38.1	21.3	31.8	31.8	60.5	22.4	22.9	To be specified by the purchaser	35.1	6.4	3.0	23.6	9.7	82.6	22.2	4	3/4	108.0
20	3/4	130.0	25.4	44.5	26.7	35.1	35.1	69.9	27.7	28.2		42.9	6.4	3.0	29.0	11.2	88.9	22.2	4	3/4	114.3
25	1	149.4	28.4	52.3	33.5	41.1	41.1	73.2	34.5	35.1		50.8	6.4	3.0	35.8	12.7	101.6	25.4	4	7/8	127.0
32	1-1/4	158.8	28.4	63.5	42.2	41.1	41.1	73.2	43.2	43.7		63.5	6.4	4.8	44.5	14.2	111.3	25.4	4	7/8	127.0
40	1-1/2	177.8	31.8	69.9	48.3	44.5	44.5	82.6	49.5	50.0		73.2	6.4	6.4	50.5	15.7	124.0	28.6	4	1	139.7
50	2	215.9	38.1	104.6	60.5	57.2	57.2	101.6	62.0	62.5		91.9	6.4	7.9	63.5	17.5	165.1	25.4	8	7/8	146.1
65	2-1/2	244.3	41.1	124.0	73.2	63.5	63.5	104.6	74.7	75.4		104.6	6.4	7.9	76.2	19.1	190.5	28.6	8	1	158.8
80	3	266.7	47.8	133.4	88.9	0.0	73.2	117.3	0.0	91.4		127.0	6.4	9.7			203.2	31.8	8	1-1/8	177.8
100	4	311.2	53.8	162.1	114.3	0.0	90.4	124.0	0.0	116.8		157.2	6.4	11.2			241.3	34.9	8	1-1/4	196.9
125	5	374.7	73.2	196.9	141.2	0.0	104.6	155.4	0.0	144.5		185.7	6.4	11.2			292.1	41.3	8	1-1/2	247.7
150	6	393.7	82.6	228.6	168.4	0.0	119.1	171.5	0.0	171.5		215.9	6.4	12.7			317.5	38.1	12	1-3/8	260.4
200	8	482.6	91.9	292.1	219.2	0.0	142.7	212.9	0.0	222.3		269.7	6.4	12.7			393.7	44.5	12	1-5/8	292.1
250	10	584.2	108.0	368.3	273.1	0.0	177.8	254.0	0.0	277.4		323.9	6.4	12.7			482.6	50.8	12	1-7/8	336.6
300	12	673.1	124.0	450.9	323.9	0.0	218.9	282.4	0.0	328.2		381.0	6.4	12.7			571.5	54.0	16	2	374.7
350	14	749.3	133.4	495.3	355.6	0.0	241.3	298.5	0.0	360.2		412.8	6.4	12.7			635.0	60.3	16	2-1/4	406.4
400	16	825.5	146.1	552.5	406.4	0.0	260.4	311.2	0.0	411.2		469.9	6.4	12.7			704.9	66.7	16	2-1/2	444.5
450	18	914.4	162.1	596.9	457.2	0.0	276.4	327.2	0.0	462.3		533.4	6.4	12.7			774.7	73.0	16	2-3/4	495.3
500	20	984.3	177.8	641.4	508.0	0.0	292.1	355.6	0.0	514.4		584.2	6.4	12.7			831.9	79.4	16	3	539.8
600	24	1168.4	203.2	762.0	609.6	0.0	330.2	406.4	0.0	616.0		692.2	6.4	12.7			990.6	92.1	16	3-1/2	616.0

Size		Approximate piece weight in Kilograms					
DN	NPS	Blind	Weld Neck	Slip-On	Lap Joint	Socket Weld	Threaded
15	1/2	1.90	2.10	1.80	1.80	1.81	1.80
20	3/4	2.72	2.72	2.27	2.27	2.81	2.27
25	1	4.08	3.86	3.40	3.40	3.61	3.40
32	1-1/4	4.30	4.54	4.10	4.09	4.99	4.10
40	1-1/2	5.90	5.90	5.45	5.40	6.76	5.45
50	2	11.30	10.89	10.50	9.53	10.89	10.50
65	2-1/2	16.00	16.34	15.80	13.15	16.34	15.80
80	3	21.79	21.79		17.24		
100	4	33.11	31.30		29.00		
125	5	60.00	59.02		54.00		
150	6	75.00	74.91		62.00		
200	8	136.98	123.83		129.73		
250	10	229.97	205.93		220.19		
300	12	316.00	306.00		286.02		
350	14	421.00	416.00		404.06		
400	16	559.00	567.50		522.10		
450	18	761.00	736.00		669.65		
500	20	967.00	929.00		805.85		
600	24	1568.00	1504.00		1285.55		

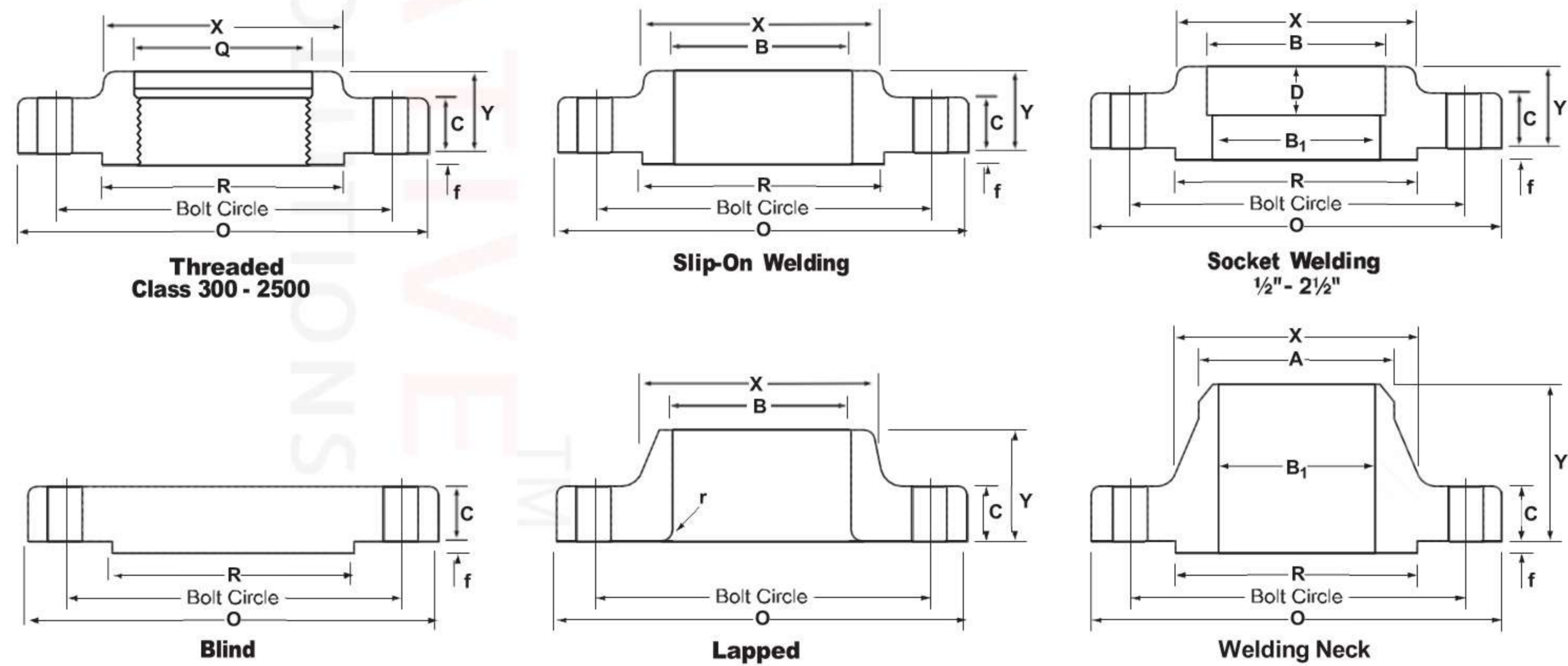

**Notes:**

1. Flange Raised Face Diameter and Height are based on a standard Raised Face, other flange facing types will change the "R" and "f" dimensions
2. For Threaded Flanges in this Class a counterbore is required. NPS Sizes 50 and smaller will have a 6.4 counterbore and NPS sizes 65 and larger will have a 9.5 counterbore.
3. All dimensions are converted from the ASME B16.5 inch system to millimetres using 1" = 25.4 mm and rounded to one decimal point, except where noted.
4. All weights are approximate only.

**ANSI CLASS 1500**



ANSI CLASS 2500

Size		Length Through Hub				Bore				Bolt Information									
DN mm	Nominal Pipe Size inch	Outside Diameter of Flange O	Thickness of Flange Min. C	Diameter of Hub X	Hub Diameter Beginning of Chamfer Welding Neck A	Threaded Y	Lapped Y	Welding Neck Y	Lapped Min. B	Welding Neck/Socket Welding B1	Diameter of Raised Face R	Height of Raised Face f	Corner Radius of Bore of Lapped Flange and Pipe r	Counter-bore Diameter Threaded Flange Min. Q	Diameter of Bolt Circle	Diameter of Bolt Holes	Number of Bolts	Diameter of Bolts (inch)	Length of Stud Bolts 6.4mm Raised Face
15	1/2	133.4	30.2	42.9	21.3	39.6	39.6	73.2	22.9	To be specified by the purchaser	35.1	6.4	3.0	23.6	88.9	22.2	4	3/4	120.7
20	3/4	139.7	31.8	50.8	26.7	42.9	42.9	79.2	28.2		42.9	6.4	3.0	29.0	95.3	22.2	4	3/4	127.0
25	1	158.8	35.1	57.2	33.5	47.8	47.8	88.9	35.1		50.8	6.4	3.0	35.8	108.0	25.4	4	7/8	139.7
32	1-1/4	184.2	38.1	73.2	42.2	52.3	52.3	95.3	43.7		63.5	6.4	4.8	44.5	130.0	28.6	4	1	152.4
40	1-1/2	203.2	44.5	79.2	48.3	60.5	60.5	111.3	50.0		73.2	6.4	6.4	50.5	146.1	31.8	4	1-1/8	171.5
50	2	235.0	50.8	95.3	60.5	69.9	69.9	127.0	62.5		91.9	6.4	7.9	63.5	171.5	28.6	8	1	177.8
65	2-1/2	266.7	57.2	114.3	73.2	79.2	79.2	142.7	75.4		104.6	6.4	7.9	76.2	196.9	31.8	8	1-1/8	196.9
80	3	304.8	66.5	133.4	88.9		91.9	168.1	91.4		127.0	6.4	9.7		228.6	34.9	8	1-1/4	222.3
100	4	355.6	76.2	165.1	114.3		108.0	190.5	116.8		157.2	6.4	11.2		273.1	41.3	8	1-1/2	254.0
125	5	419.1	91.9	203.2	141.2		130.0	228.6	144.5		185.7	6.4	11.2		323.9	47.6	8	1-3/4	298.5
150	6	482.6	108.0	235.0	168.4		152.4	273.1	171.5		215.9	6.4	12.7		368.3	54.0	8	2	342.9
200	8	552.5	127.0	304.8	219.2		177.8	317.5	222.3		269.7	6.4	12.7		438.2	54.0	12	2	381.0
250	10	673.1	165.1	374.7	273.1		228.6	419.1	277.4		323.9	6.4	12.7		539.8	66.7	12	2-1/2	489.0
300	12	762.0	184.2	441.5	323.9		254.0	463.6	328.2		381.0	6.4	12.7		619.3	73.0	12	2-3/4	539.8

Size		Approximate piece weight in Kilograms			
DN	NPS	Blind	Weld Neck	Lap Joint	Threaded
15	1/2	3.18	3.18	3.00	3.18
20	3/4	4.54	4.08	3.63	4.08
25	1	5.44	5.45	4.99	5.44
32	1-1/4	8.16	9.07	7.26	8.16
40	1-1/2	10.44	11.35	9.99	11.00
50	2	17.71	19.07	16.80	17.25
65	2-1/2	25.42	23.61	24.06	24.97
80	3	39.04	42.68	36.32	
100	4	60.38	64.00	54.48	
125	5	101.15	110.68	92.53	
150	6	156.63	176.46	143.01	
200	8	240.62	261.27	213.38	
250	10	465.36	484.43	408.60	
300	12	664.06	692.35	572.95	

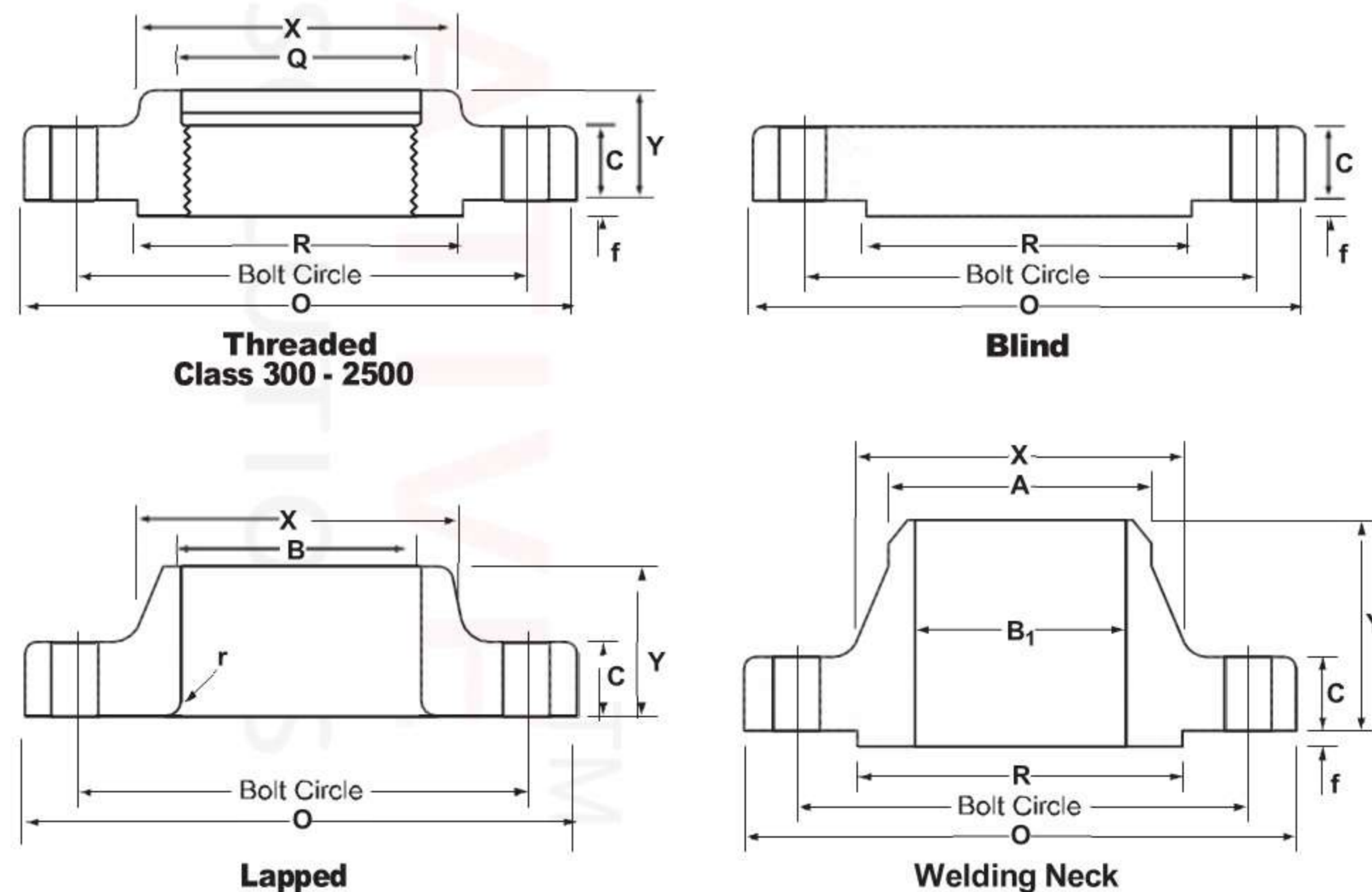

Notes:

1. Flange Raised Face Diameter and Height are based on a standard Raised Face, other flange facing types will change the "R" and "f" dimensions
2. For Threaded Flanges in this Class a counterbore is required. NPS Sizes 50 and smaller will have a 6.4 counterbore and NPS sizes 65 and larger will have a 9.5 counterbore.
3. All dimensions are converted from the ASME B16.5 inch system to millimetres using 1" = 25.4 mm and rounded to one decimal point, except where noted.
4. All weights are approximate only.



**PRESSURE TEMPERATURE RATINGS BAR**

Temp °C	Class 150			Class 300			Class 600			Class 900			Class 1500			Class 2500		
	304	316	304L 316L	304	316	304L 316L	304	316	304L 316L	304	316	304L 316L	304	316	304L 316L	304	316	304L 316L
-29 to 38	19.0	19.0	15.9	49.6	49.6	41.4	99.3	99.3	82.7	148.9	148.9	124.1	248.2	248.2	206.8	413.7	413.7	344.7
50	18.3	18.4	15.3	47.8	48.1	40.0	95.6	96.2	80.0	143.5	144.3	120.1	239.1	240.6	200.1	398.5	400.9	333.5
100	15.7	16.2	13.3	40.9	42.2	34.8	81.7	84.4	69.6	122.6	126.6	104.4	204.3	211.0	173.9	340.4	351.6	289.9
150	14.2	14.8	12.0	37.0	38.5	31.4	74.0	77.0	62.8	111.0	115.5	94.2	185.0	192.5	157.0	308.4	320.8	261.6
200	13.2	13.7	11.2	34.5	35.7	29.2	69.0	71.3	58.3	103.4	107.0	87.5	172.4	178.3	145.8	287.3	297.2	243.0
250	12.1	12.1	10.5	32.5	33.4	27.5	65.0	66.8	54.9	97.5	100.1	82.4	162.4	166.9	137.3	270.7	278.1	228.9
300	10.2	10.2	10.0	30.9	31.6	26.1	61.8	63.2	52.1	92.7	94.9	78.2	154.6	158.1	130.3	257.6	263.5	217.2
325	9.3	9.3	9.3	30.2	30.9	25.5	60.4	61.8	51.0	90.7	92.7	76.4	151.1	154.4	127.4	251.9	257.4	212.3
350	8.4	8.4	8.4	29.6	30.3	25.1	59.3	60.7	50.1	88.9	91.0	75.2	148.1	151.6	125.4	246.9	252.7	208.9
375	7.4	7.4	7.4	29.0	29.9	24.8	58.1	59.8	49.5	87.1	89.6	74.3	145.2	149.4	123.8	241.9	249.0	206.3
400	6.5	6.5	6.5	28.4	29.4	24.3	56.9	58.9	48.6	85.3	88.3	72.9	142.2	147.2	121.5	237.0	245.3	202.5
425	5.5	5.5	5.5	28.0	29.1	23.9	56.0	58.3	47.7	84.0	87.4	71.6	140.0	145.7	119.3	233.3	242.9	198.8
450	4.6	4.6	4.6	27.4	28.8	23.4	54.8	57.7	46.8	82.2	86.5	70.2	137.0	144.2	117.1	228.4	240.4	195.1
475	3.7	3.7		26.9	28.7		53.9	57.3		80.8	86.0		134.7	143.4		224.5	238.9	
500	2.8	2.8		26.5	28.2		53.0	56.5		79.5	84.7		132.4	140.9		220.7	235.0	
538	1.4	1.4		24.4	25.2		48.9	50.0		73.3	75.2		122.1	125.5		203.6	208.9	
550				23.6	25.0		47.1	49.8		70.7	74.8		117.8	124.9		196.3	208.0	
575				20.8	24.0		41.7	47.9		62.5	71.8		104.2	119.7		173.7	199.5	
600				16.9	19.9		33.8	39.8		50.6	59.7		84.4	99.5		140.7	165.9	
625				13.8	15.8		27.6	31.6		41.4	47.4		68.9	79.1		114.9	131.8	
650				11.3	12.7		22.5	25.3		33.8	38.0		56.3	63.3		93.8	105.5	
675				9.3	10.3		18.7	20.6		28.0	31.0		46.7	51.6		77.9	86.0	
700				8.0	8.4		16.1	16.8		24.1	25.1		40.1	41.9		66.9	69.8	
725				6.8	7.0		13.5	14.0		20.3	21.0		33.8	34.9		56.3	58.2	
750				5.8	5.9		11.6	11.7		17.3	17.6		28.9	29.3		48.1	48.9	
775				4.6	4.6		9.0	9.0		13.7	13.7		22.8	22.8		38.0	38.0	
800				3.5	3.5		7.0	7.0		10.5	10.5		17.4	17.4		29.2	29.2	
816				2.8	2.8		5.9	5.9		8.6	8.6		14.1	14.1		23.8	23.8	

**Notes:**

1. The Pressure-Temperature information was obtained from ASME B16.5-2009. For full details regarding the Pressure-Temperature ratings of other materials refer to the standard.
2. Pressure Ratings are maximum allowable working gauge pressures in bar at the temperatures shown for the applicable material.
3. For ASTM A182 and ASTM A240 material grades 304 and 316, where the temperature exceeds 538°C the Carbon (C) content must be  $\geq 0.04\%$ .
4. For ASTM A182 and ASTM A240 material grade 304L, it is not to be used when the temperature exceeds 425°C.



**Head Office:**

Ground Floor Shop No. 8/12, Plot No. 25/33, Ardesherdadi Street,  
C. P. Tank, Girgaon, Mumbai-400004 Maharashtra, India

**Maharashtra Factory Unit-I**

Plot Number 1776, Road Number 22, Steel Market Kalamboli, Panvel,  
Navi Mumbai-410218 Maharashtra, India

**Gujarat Unit-II**

Plot No.12, Jorajina Muada Post, Talod, Sabarkantha-383215 Gujarat-India

**Gujarat Uni-III**

Unit-II plot no. 275/276 horizon industrial park nh 48, at bamangam,  
tal karjan kandari karjan vadodara gujarat 391210 India

[www.creativepiping.com](http://www.creativepiping.com) | +918591195895 | [sale@creativepiping.com](mailto:sale@creativepiping.com)