

## Swaged Nipples

MSS-SP-95-2006

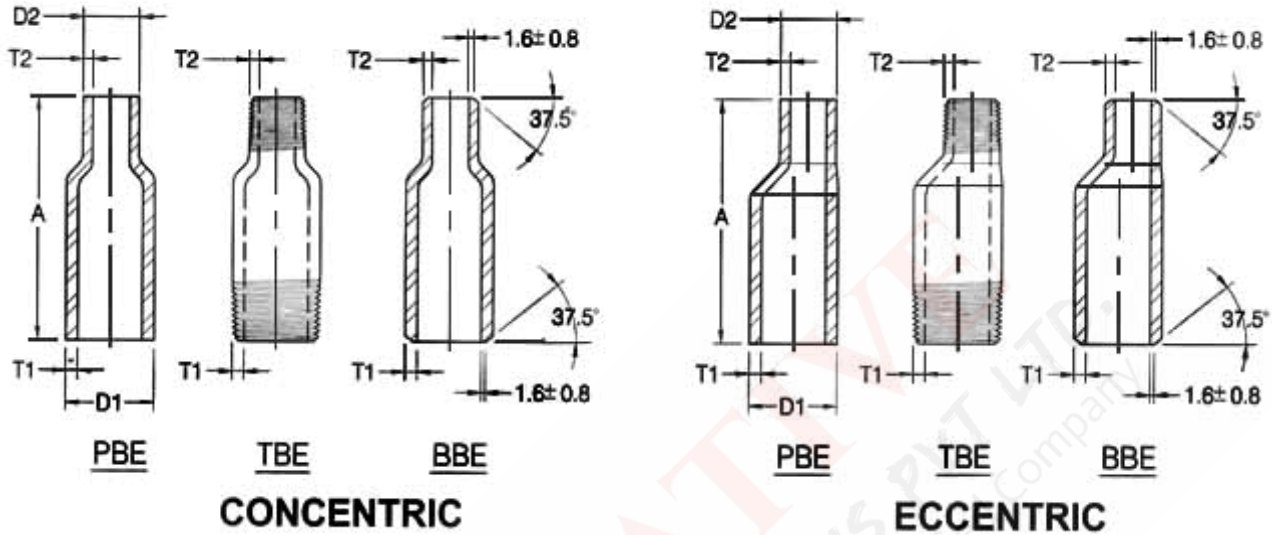

Nominal Pipe Size (NPS)	Outside Diameter		End To End "A"	Wall Thickness							
	Large End D1	Small End D2		T1				T2			
				Sch40 (STD)	Sch80 (XS)	Sch160	XXS	Sch40 (STD)	Sch80 (XS)	Sch160	XXS
1/4"x1/8"	13.7	10.3	57	2.2	3.0	3.7	6.1	1.7	2.4		
3/8"x1/8"	17.1	10.3	64	2.3	3.2	4.0	6.4	1.7	2.4		
3/8"x1/4"	17.1	13.7	64	2.3	3.2	4.0	6.4	2.2	3.0		
1/2"x1/8"	21.3	10.3	70	2.8	3.7	4.8	7.5	1.7	2.4		
1/2"x1/4"	21.3	13.7	70	2.8	3.7	4.8	7.5	2.2	3.0		
1/2"x3/8"	21.3	17.1	70	2.8	3.7	4.8	7.5	2.3	3.2		
3/4"x1/8"	26.7	10.3	76	2.9	3.9	5.6	7.8	1.7	2.4		
3/4"x1/4"	26.7	13.7	76	2.9	3.9	5.6	7.8	2.2	3.0		
3/4"x3/8"	26.7	17.1	76	2.9	3.9	5.6	7.8	2.3	3.2		
3/4"x1/2"	26.7	21.3	76	2.9	3.9	5.6	7.8	2.8	3.7	4.8	7.5
1"x1/8"	33.4	10.3	89	3.4	4.5	6.4	9.1	1.7	2.4		
1"x1/4"	33.4	13.7	89	3.4	4.5	6.4	9.1	2.2	3.0		
1"x3/8"	33.4	17.1	89	3.4	4.5	6.4	9.1	2.3	3.2		
1"x1/2"	33.4	21.3	89	3.4	4.5	6.4	9.1	2.8	3.7	4.8	7.5
1"x3/4"	33.4	26.7	89	3.4	4.5	6.4	9.1	2.9	3.9	5.6	7.8
1-1/4"x1/8"	42.2	10.3	102	3.6	4.9	6.4	9.7	1.7	2.4		
1-1/4"x1/4"	42.2	13.7	102	3.6	4.9	6.4	9.7	2.2	3.0		
1-1/4"x3/8"	42.2	17.1	102	3.6	4.9	6.4	9.7	2.3	3.2		
1-1/4"x1/2"	42.2	21.3	102	3.6	4.9	6.4	9.7	2.8	3.7	4.8	7.5
1-1/4"x3/4"	42.2	26.7	102	3.6	4.9	6.4	9.7	2.9	3.9	5.6	7.8
1-1/4"x1"	42.2	33.4	102	3.6	4.9	6.4	9.7	3.4	4.5	6.4	9.1
1-1/2"x1/8"	48.3	10.3	114	3.7	5.1	7.1	10.2	1.7	2.4		
1-1/2"x1/4"	48.3	13.7	114	3.7	5.1	7.1	10.2	2.2	3.0		
1-1/2"x3/8"	48.3	17.1	114	3.7	5.1	7.1	10.2	2.3	3.2		
1-1/2"x1/2"	48.3	21.3	114	3.7	5.1	7.1	10.2	2.8	3.7	4.8	7.5
1-1/2"x3/4"	48.3	26.7	114	3.7	5.1	7.1	10.2	2.9	3.9	5.6	7.8
1-1/2"x1"	48.3	33.4	114	3.7	5.1	7.1	10.2	3.4	4.5	6.4	9.1
1-1/2"x1-1/4"	48.3	42.2	114	3.7	5.1	7.1	10.2	3.6	4.9	6.4	9.7
2"x1/8"	60.3	10.3	165	3.9	5.5	8.7	11.1	1.7	2.4		
2"x1/4"	60.3	13.7	165	3.9	5.5	8.7	11.1	2.2	3.0		
2"x3/8"	60.3	17.1	165	3.9	5.5	8.7	11.1	2.3	3.2		
2"x1/2"	60.3	21.3	165	3.9	5.5	8.7	11.1	2.8	3.7	4.8	7.5

(Continued)

### Swaged Nipples

MSS-SP-95-2006

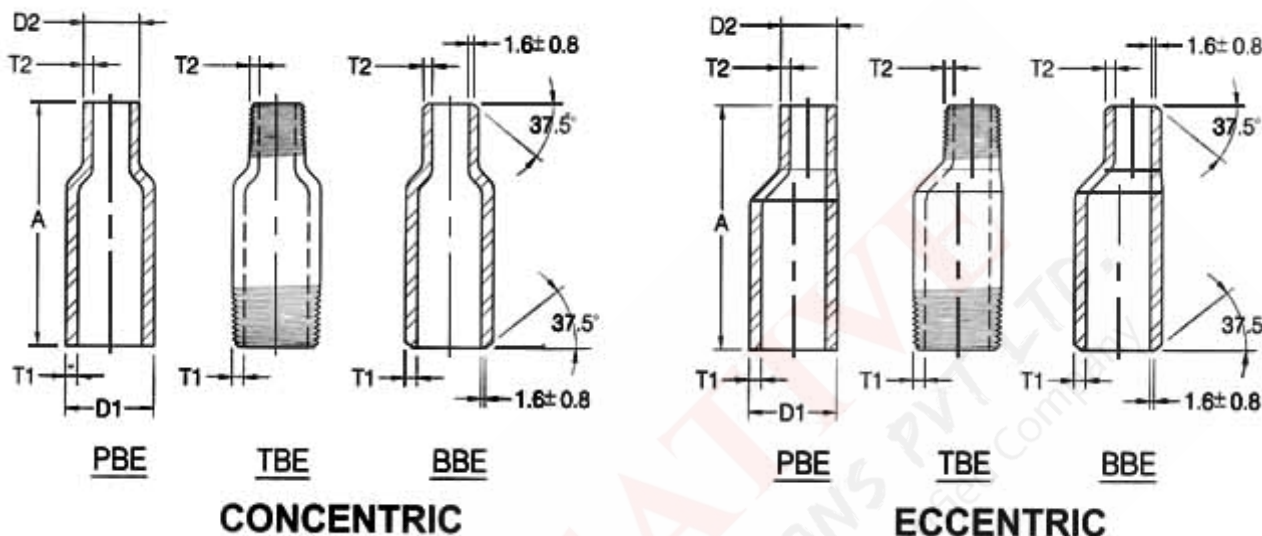

(Continued)

Nominal Pipe Size (NPS)	Outside Diameter		End To End "A"	Wall Thickness							
	Large End D1	Small End D2		T1				T2			
				Sch40 (STD)	Sch80 (XS)	Sch160	XXS	Sch40 (STD)	Sch80 (XS)	Sch160	XXS
2"x3/4"	60.3	26.7	165	3.9	5.5	8.7	11.1	2.9	3.9	5.6	7.8
2"x1"	60.3	33.4	165	3.9	5.5	8.7	11.1	3.4	4.5	6.4	9.1
2"x1-1/4"	60.3	42.2	165	3.9	5.5	8.7	11.1	3.6	4.9	6.4	9.7
2"x1-1/2"	60.3	48.3	165	3.9	5.5	8.7	11.1	3.7	5.1	7.1	10.2
2-1/2"x1/8"	73.0	10.3	178	5.2	7.0	9.5	14.0	1.7	2.4		
2-1/2"x1/4"	73.0	13.7	178	5.2	7.0	9.5	14.0	2.2	3.0		
2-1/2"x3/8"	73.0	17.1	178	5.2	7.0	9.5	14.0	2.3	3.2		
2-1/2"x1/2"	73.0	21.3	178	5.2	7.0	9.5	14.0	2.8	3.7	4.8	7.5
2-1/2"x3/4"	73.0	26.7	178	5.2	7.0	9.5	14.0	2.9	3.9	5.6	7.8
2-1/2"x1"	73.0	33.4	178	5.2	7.0	9.5	14.0	3.4	4.5	6.4	9.1
2-1/2"x1-1/4"	73.0	42.2	178	5.2	7.0	9.5	14.0	3.6	4.9	6.4	9.7
2-1/2"x1-1/2"	73.0	48.3	178	5.2	7.0	9.5	14.0	3.7	5.1	7.1	10.2
2-1/2"x2"	73.0	60.3	178	5.2	7.0	9.5	14.0	3.9	5.5	8.7	11.1
3"x1/8"	88.9	10.3	203	5.5	7.6	11.1	15.2	1.7	2.4	3.2	4.8
3"x1/4"	88.9	13.7	203	5.5	7.6	11.1	15.2	2.2	3.0	3.7	6.1
3"x3/8"	88.9	17.1	203	5.5	7.6	11.1	15.2	2.3	3.2	4.0	6.4
3"x1/2"	88.9	21.3	203	5.5	7.6	11.1	15.2	2.8	3.7	4.8	7.5
3"x3/4"	88.9	26.7	203	5.5	7.6	11.1	15.2	2.9	3.9	5.6	7.8
3"x1"	88.9	33.4	203	5.5	7.6	11.1	15.2	3.4	4.5	6.4	9.1
3"x1-1/4"	88.9	42.2	203	5.5	7.6	11.1	15.2	3.6	4.9	6.4	9.7
3"x1-1/2"	88.9	48.3	203	5.5	7.6	11.1	15.2	3.7	5.1	7.1	10.2
3"x2"	88.9	60.3	203	5.5	7.6	11.1	15.2	3.9	5.5	8.7	11.1
3"x2-1/2"	88.9	73.0	203	5.5	7.6	11.1	15.2	5.2	7.0	9.5	14.0
3-1/2"x1/8"	101.6	10.3	203	5.7	8.1			1.7	2.4		
3-1/2"x1/4"	101.6	13.7	203	5.7	8.1			2.2	3.0		
3-1/2"x3/8"	101.6	17.1	203	5.7	8.1			2.3	3.2		
3-1/2"x1/2"	101.6	21.3	203	5.7	8.1			2.8	3.7	4.8	7.5
3-1/2"x3/4"	101.6	26.7	203	5.7	8.1			2.9	3.9	5.6	7.8
3-1/2"x1"	101.6	33.4	203	5.7	8.1			3.4	4.5	6.4	9.1
3-1/2"x1-1/4"	101.6	42.2	203	5.7	8.1			3.6	4.9	6.4	9.7

(Continued)

## Swaged Nipples

MSS-SP-95-2006

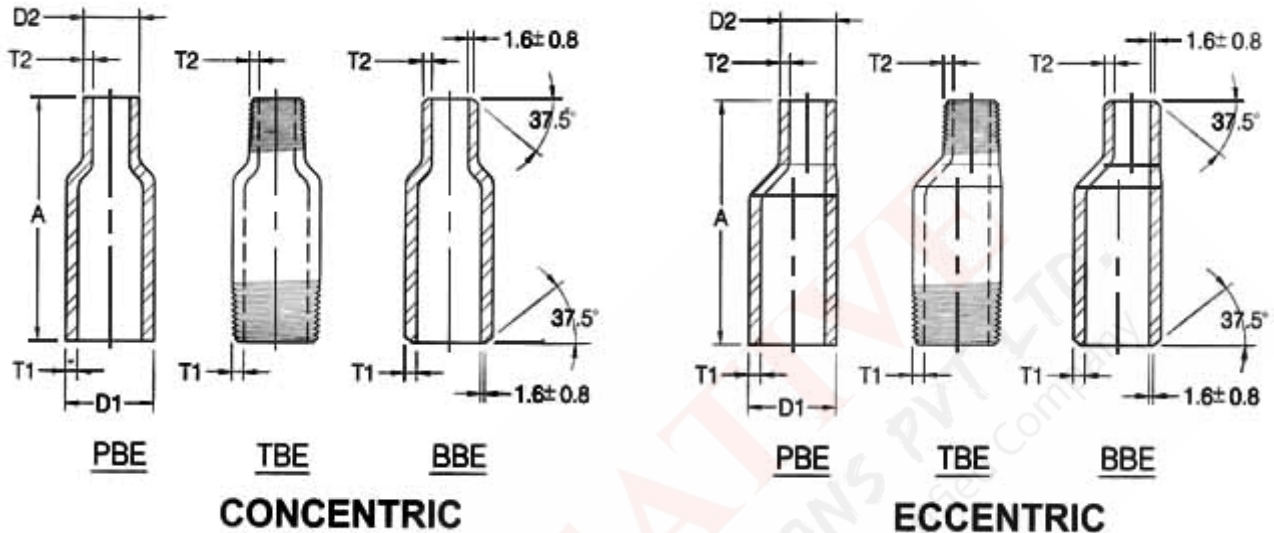

(Continued)

Nominal Pipe Size (NPS)	Outside Diameter		End To End "A"	Wall Thickness							
	Large End D1	Small End D2		T1				T2			
				Sch40 (STD)	Sch80 (XS)	Sch160	XXS	Sch40 (STD)	Sch80 (XS)	Sch160	XXS
3-1/2"x1-1/2"	101.6	48.3	203	5.7	8.1			3.7	5.1	7.1	10.2
3-1/2"x2"	101.6	60.3	203	5.7	8.1			3.9	5.5	8.7	11.1
3-1/2"x2-1/2"	101.6	73.0	203	5.7	8.1			5.2	7.0	9.5	14.0
3-1/2"x3"	101.6	88.9	203	5.7	8.1			5.5	7.6	11.1	15.2
4"x1/4"	114.3	13.7	229	6.0	8.6	13.5	17.1	2.2	3.0		
4"x3/8"	114.3	17.1	229	6.0	8.6	13.5	17.1	2.3	3.2		
4"x1/2"	114.3	21.3	229	6.0	8.6	13.5	17.1	2.8	3.7	4.8	7.5
4"x3/4"	114.3	26.7	229	6.0	8.6	13.5	17.1	2.9	3.9	5.6	7.8
4"x1"	114.3	33.4	229	6.0	8.6	13.5	17.1	3.4	4.5	6.4	9.1
4"x1-1/4"	114.3	42.2	229	6.0	8.6	13.5	17.1	3.6	4.9	6.4	9.7
4"x1-1/2"	114.3	48.3	229	6.0	8.6	13.5	17.1	3.7	5.1	7.1	10.2
4"x2"	114.3	60.3	229	6.0	8.6	13.5	17.1	3.9	5.5	8.7	11.1
4"x2-1/2"	114.3	73.0	229	6.0	8.6	13.5	17.1	5.2	7.0	9.5	14.0
4"x3"	114.3	88.9	229	6.0	8.6	13.5	17.1	5.5	7.6	11.1	15.2
4"x3-1/2"	114.3	101.6	229	6.0	8.6	13.5	17.1	5.7	8.1		

(1) Dimensions in Millimeters.

(2) Wall Thickness : T1 & T2 in accordance with ASME B36.10M

PBE : Plain Both Ends

BBE : Bevel Both Ends

TBE : Thread Both Ends

PSE : Plain Small End

BSE : Bevel Small End

TSE : Thread Small End

PLE : Plain Large End

BLE : Bevel Large End

TLE : Thread Large End

### Dimensional Tolerance of Swaged Nipple

Nominal Pipe Size (inch)	Overall Length (mm)	Outside diameter at end		Wall Thickness (prior to threading or grooving)
		Square Cut Ends (mm)	Other End Connection (mm)	
1/8" to 3/8"	± 1.5	+ 0.40 - 0.80	± 0.80	Not less than 87.5% of nominal wall thickness
1/2" to 1-1/2"	± 1.5	+ 0.40 - 0.80	+ 1.50 - 0.80	
2" to 2-1/2"	± 3.0	± 0.80	+ 1.50 - 0.80	
3" to 4"	± 3.0	± 0.80	± 1.50	

(1) Dimensions in Millimeters.

(2) Prior to threading or grooving